



Weighing

Weighing & Measuring Solutions for Medical and Healthcare Facilities.



www.nwigroup.com.au



**World-class precision,
locally delivered.**



Table of Contents



PHYSICIAN SCALES

- 150-10-5 - DIGITAL PHYSICIAN SCALE EYE-LEVEL 3-4
- 160-10-7N - DIGITAL ATHLETIC SCALE LOW-PROFILE 5-6
- 250-10-2 - BARIATRIC HANDRAIL SCALE 7-8
- 260-10-1 - BARIATRIC HANDRAIL SCALE 9-10

WHEELCHAIR SCALES

- 350-10-3 - DUAL-RAMP WHEELCHAIR SCALE WITH HANDRAIL 11-12
- 350-10-4 DUAL-RAMP WHEELCHAIR SCALE WITH SEAT AND HANDRAIL..... 13-14
- MODEL WHEELCHAIR SCALE 15-16
- D300 WIRELESS WHEELCHAIR SCALE 17-18

BABY SCALES

- RL-DBS - DIGITAL BABY SCALE 19-20
- 650-10-1 - NEONATAL SCALE DUAL RANGE 21-22
- OS-10/25/45 - SUSPENDED INFANT SCALE 23-24
- RL-PCT-10 - PEDIATRIC CIRCUMFERENCE TAPE 25
- RL-PMM - PEDIATRIC MEASURING MAT 26
- GROWTH CHART BOY AND GIRL 27-28

HOME HEALTH SCALES

- RL-440HH - DIGITAL HOME HEALTH SCALE 29-30
- DHH-10 - DIGITAL HOME HEALTH SCALE 31

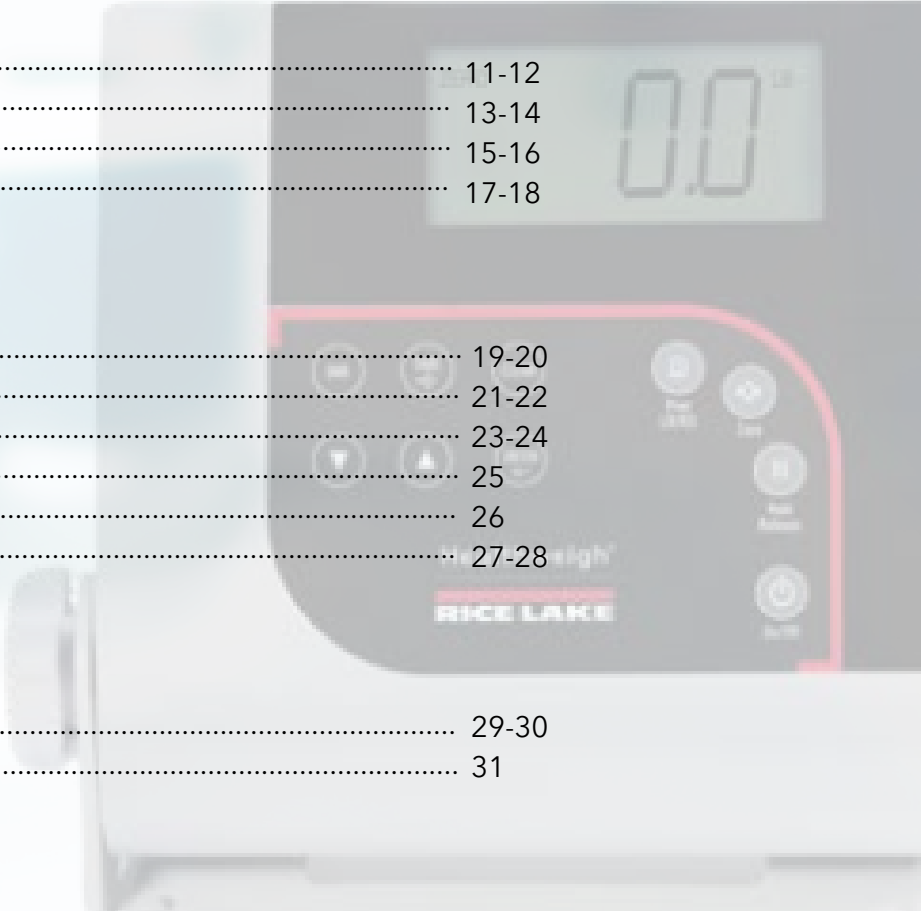



Digital Physician Scale Eye-Level

150-10-5

The Rice Lake 150-10-5 digital physician scale is designed for both modern appearance and contemporary function with forward-thinking features. Offering an eye-level digital display, the 150-10-5 physician scale clearly displays weight. Seamlessly capture height and weight with the integrated height rod, which tucks neatly within the scale column. The large, stable scale base is both comfortable and easily transported with two built-in rubber wheels. Whether powered from an optional AC adaptor or standard alkaline batteries, the 150-10-5 is easy to use. Its large push-button display lights up for easy viewing and an audible beep sounds at the end of each weigh cycle.

SPECIFICATIONS

- Capacity: 250 kg x 0.1 kg
- Platform Dimensions: (W x L x H) 36.83cm x 36.83cm x 7.62cm
- Power: 9V DC, provided by six AA alkaline batteries (included) or AC adaptor (optional)
- Battery Type: Six AA alkaline (included)
- Operating Temperature: 14° C to 40° C
- Battery Use: 25 hours continuous use with batteries
- Automatic power-off can be configured
- Display: 5-digit LCD display, 1.9 mm digit height
- Warranty: One-year limited warranty

FEATURES

- Rubber wheels for easy transport
- Large, stable scale base
- Push-button LCD display
- BMI (body mass index) function
- Hold function
- Units of measure: lb only, kg only, lb/kg
- Motiontrap™ movement compensation technology
- EHR capable
- Integrated height rod measures from 70 cm to 208 cm



Physician Scales - Digital



DIMENSIONS

CENTIMETERS

A	137.2
B	57
C	37.5
D	7.6

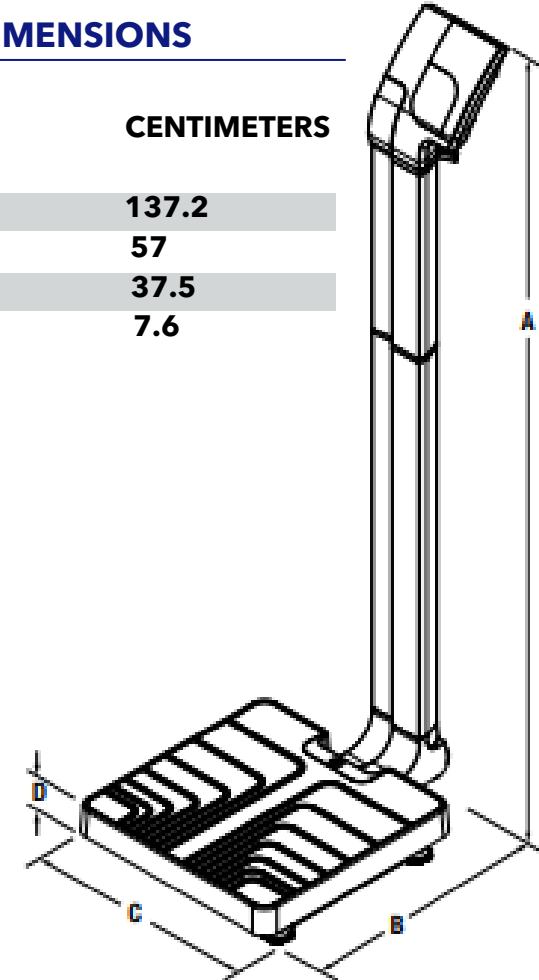

SHIPPING WEIGHT

	L (CM)	W (CM)	H (CM)	PACKAGE WGT. (KG)	DIM WGT. (KG)	SHIPPING WGT. (KG)
150-10-5	76.2	45.72	22.86	11.79	15.87	15.87
150-10-5BT	76.2	45.72	22.86	11.79	15.87	15.87

DIGITAL PHYSICIAN SCALE - EYE-LEVEL

MODEL	CAPACITY	COMMUNICATION
150-10-5	(250 kg × 0.1 kg)	USB
150-10-5BT	(250 kg × 0.1 kg)	USB and Bluetooth 2.0
150-10-5BLE	(250 kg × 0.1 kg)	Bluetooth BLE 4.0

OPTIONS

- 9V DC adaptor, 120 V/230 V auto switching Medical grade power supply
- 9V DC adaptor, 120 V/230V auto switching
- 9V DC adaptor, 230 V
- Tally Roll Printer
- Printer cable, 25-pin D-Sub male to RJ-45, 6 ft



Digital Athletic Scale Low Profile

160-10-7N

Rice Lake's 160-10-7N low-profile digital athletic scale offers superior accuracy and built-in durability for repetitive use in settings where a Legal for Trade scale is needed. It is slip-resistant, demands little space and is exceptionally portable. The 160-10-7N low-profile scale features a very low, 41.91mm rise.

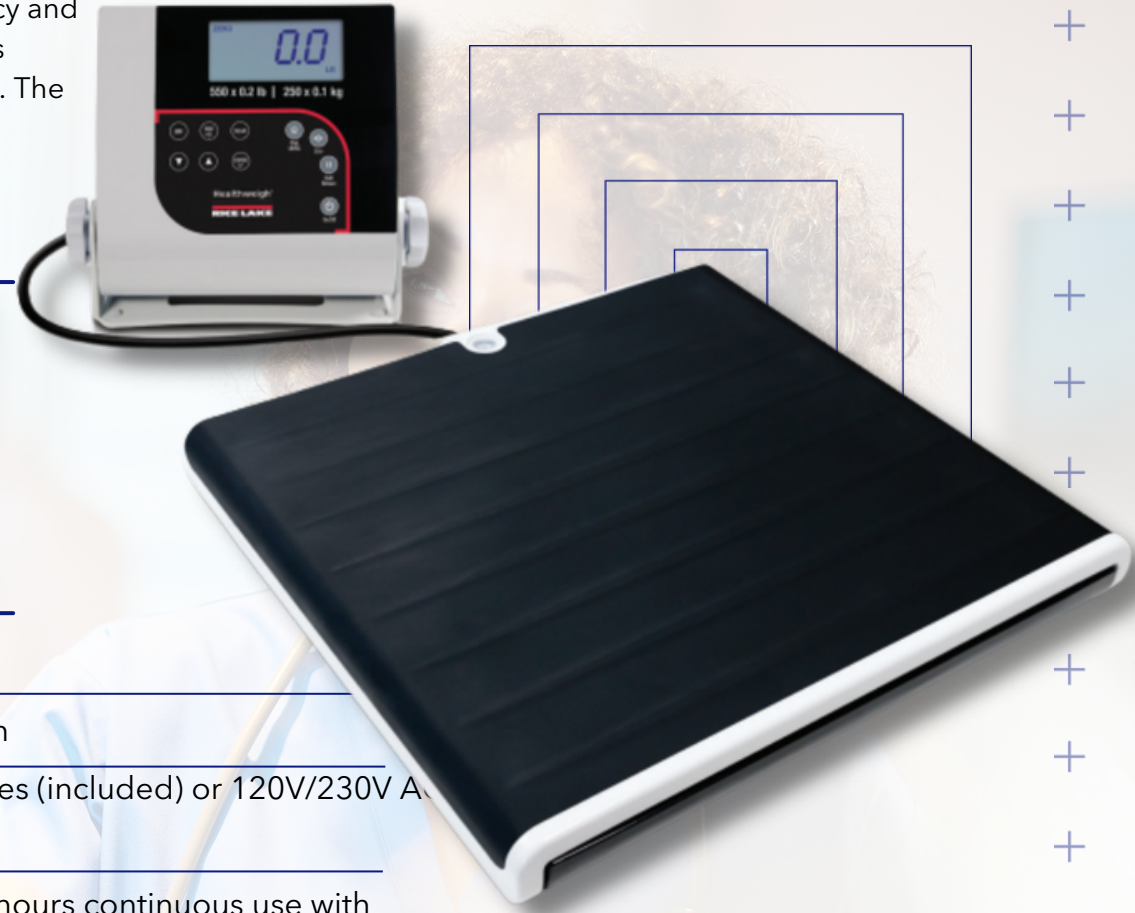

FEATURES

- Large, stable scale base
- Push-button LCD display
- Unit of Measure: lb only, kg only, lb/kg
- Motiontrap™ movement compensation technology
- EHR capable - 6 ft cable between digital display and base

SPECIFICATIONS

• Capacity	250 kg x 0.1 kg
• Platform Dimensions	(W x L x H) 36.57mm x 36.57mm x 4.19mm
• Power	9V DC, provided by six AA alkaline batteries (included) or 120V/230V AC adaptor, NEMA 1-15 plug (included)
• Battery Type	Six AA alkaline (included) Battery Use: 25 hours continuous use with batteries. Automatic power-off can be configured
• Operating Temperature	14° C to 40° C
• Display	5-digit LCD display, (1.9 mm) digit height
• Warranty	One-year limited warranty

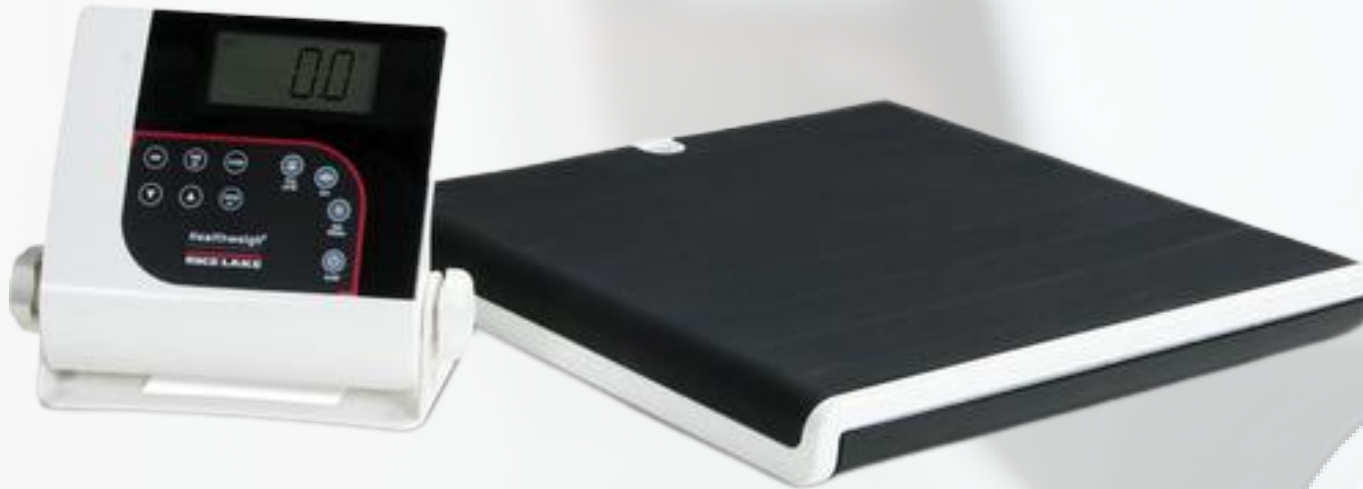

DIMENSIONS

CENTIMETERS

A	4.19
B	36.58
C	36.58
D	20
E	17

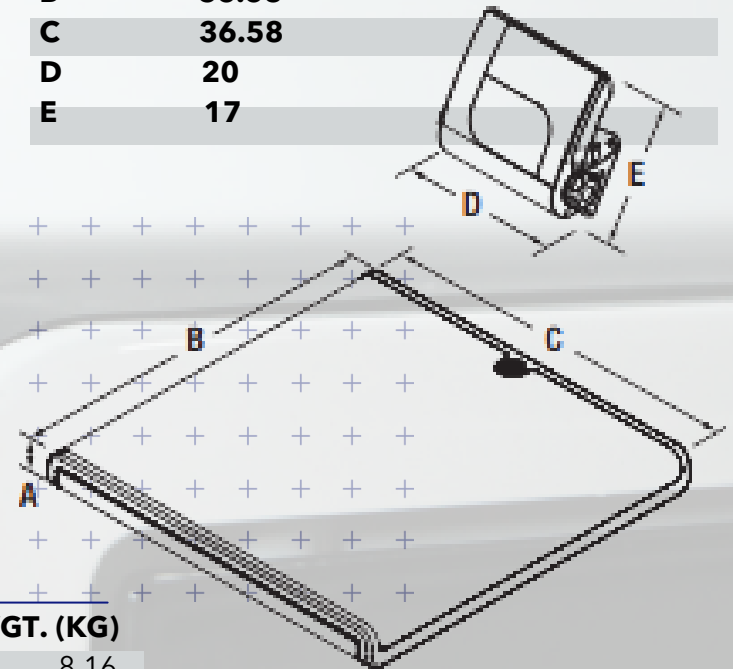

SHIPPING WEIGHT

	L (CM)	W (CM)	H (CM)	PACKAGE WGT. (KG)	DIM WGT. (KG)	SHIPPING WGT. (KG)
160-10-7	50.8	45.72	15.24	8.16	7.25	8.16
160-10-7BT	50.8	45.72	15.24	8.16	7.25	8.16

DIGITAL PHYSICIAN SCALE - LOW PROFILE

MODEL	CAPACITY	COMMUNICATION
160-10-7	(250 kg × 0.1 kg)	USB
160-10-7BT	(250 kg × 0.1 kg)	USB and Bluetooth 2.0

OPTIONS

- Carrying case
- Tally roll printer
- Printer cable, 25-pin D-Sub male to RJ-45, 6ft



Bariatric Handrail Scale

250-10-2

Rice Lake's 250-10-2 bariatric scale with handrail is designed for weighing patients who need extra support and safety. Advanced movement compensation technology eliminates error caused by involuntary movement of unsteady patients. Two heavy-duty rear wheels make it simple and effortless to move and store.

SPECIFICATIONS

Capacity: 450 kg x 0.1 kg

Platform Dimensions: (W x L x H) 50.8cm x 63.5cm x 7.62cm

Power: 9V DC, provided by six AA alkaline batteries (included) or AC adaptor (optional)

Battery Type: Six AA alkaline (included)

Battery Use: 25 hours continuous use with batteries Automatic power-off can be configured

Operating Temperature: 14° C to 40° C

Display: 5-digit LCD display, 1.9 mm digit height

Warranty: One-year limited warranty

FEATURES

- Handrails for extra support and safety
- Integrated wheels for easy transport
- Large, stable scale base
- Push-button LCD display
- BMI (body mass index) function
- Hold function
- Units of measure: lb only, kg only, lb/kg
- Motiontrap™ movement compensation technology
- EHR capable





Bariatric Handrail Scales

SHIPPING WEIGHT

	L (CM)	W (CM)	H (CM)	PACKAGE WGT. (KG)	DIM WGT. (KG)	SHIPPING WGT. (KG)
150-10-5	76.2	45.72	22.86	11.79	15.87	15.87
150-10-5BT	76.2	45.72	22.86	11.79	15.87	15.87

DIGITAL PHYSICIAN SCALE - EYE-LEVEL

MODEL	CAPACITY	COMMUNICATION
150-10-5	(250 kg × 0.1 kg)	USB
150-10-5BT	(250 kg × 0.1 kg)	USB and Bluetooth 2.0
150-10-5BLE	(250 kg × 0.1 kg)	Bluetooth BLE 4.0

OPTIONS

- 9V DC adaptor, 120 V/230 V auto switching Medical grade power supply
- 9V DC adaptor, 120 V/230V auto switching
- 9V DC adaptor, 230 V
- Tally Roll Printer
- Printer cable, 25-pin D-Sub male to RJ-45, 6 ft

DIMENSIONS

CENTIMETERS

A	137.2
B	57
C	37.5
D	7.6

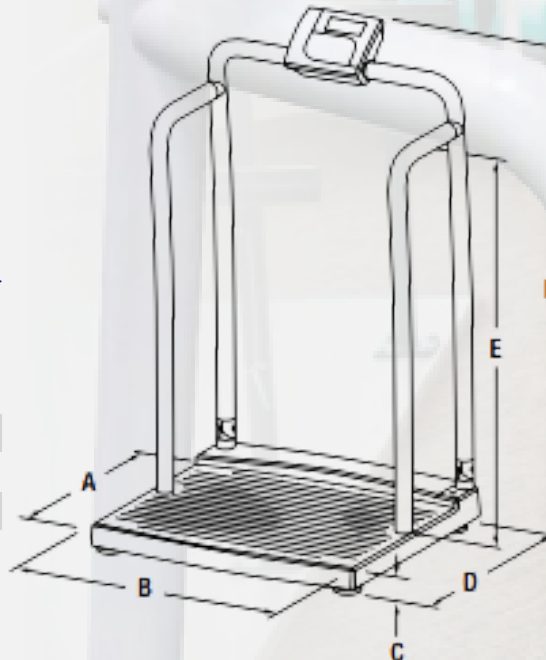



Bariatric Handrail Scale

260-10-1

Rice Lake's 260-10-1 bariatric scale with handrail is designed for weighing patients who need extra support and safety. Height and weight can be seamlessly captured with the optional integrated height rod. Advanced movement compensation technology eliminates error caused by involuntary movement of unsteady patients. Two heavy-duty rear wheels make it simple and effortless to move and store.

SPECIFICATIONS

Capacity:	360 kg x 0.1 kg
Platform Dimensions:	(W x L x H) 60.96cm x 60.96cm x 6.98cm
Height Rod Dimensions:	77-211 cm Power: 9V DC, provided by six AA alkaline batteries (included) or AC adaptor (optional)
Battery Type:	Six AA alkaline (included)
Battery Use:	25 hours continuous use with batteries Automatic power-off can be configured
Display:	5-digit LCD display, 1.9 mm digit height
Operating Temperature:	14° C to 40° C Warranty: One-year limited warranty

FEATURES

- Handrails for extra support and safety
- Integrated wheels for easy transport
- Large, stable scale base
- Push-button LCD display
- BMI (body mass index) function
- Hold function
- Units of measure: lb only, kg only, lb/kg
- Motiontrap™ movement compensation technology
- EHR capable - Optional height rod installed on-site





Bariatric Handrail Scale

260-10-1

SHIPPING WEIGHT

	L (CM)	W (CM)	H (CM)	PACKAGE WGT. (KG)	DIM WGT. (KG)	SHIPPING WGT. (KG)
150-10-5	76.2	45.72	22.86	11.79	15.87	15.87
150-10-5BT	76.2	45.72	22.86	11.79	15.87	15.87

DIGITAL PHYSICIAN SCALE - EYE-LEVEL

MODEL	CAPACITY	COMMUNICATION
150-10-5	(250 kg × 0.1 kg)	USB
150-10-5BT	(250 kg × 0.1 kg)	USB and Bluetooth 2.0
150-10-5BLE	(250 kg × 0.1 kg)	Bluetooth BLE 4.0

OPTIONS

- 9V DC adaptor, 120 V/230 V auto switching Medical grade power supply
- 9V DC adaptor, 120 V/230V auto switching
- 9V DC adaptor, 230 V
- Tally Roll Printer
- Printer cable, 25-pin D-Sub male to RJ-45, 6 ft

DIMENSIONS

CENTIMETERS

A	137.2
B	57
C	37.5
D	7.6

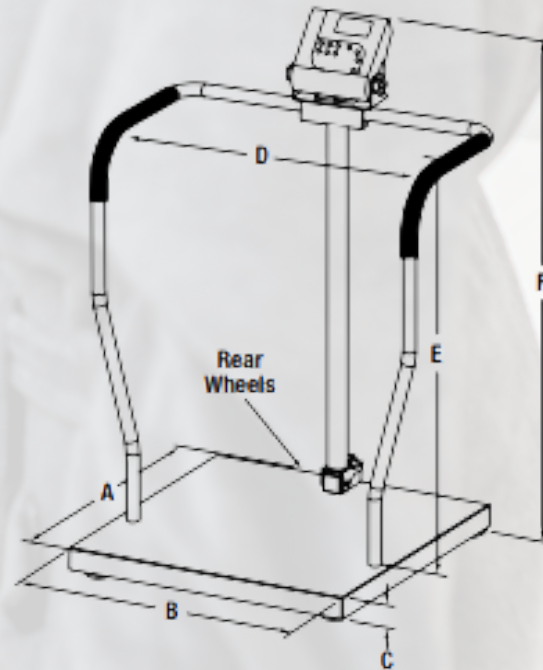



Dual-Ramp Wheelchair Scale with Handrail

350-10-3

Rice Lake's 350-10-3 dual-ramp wheelchair scale with handrail allows high capacity, accurate weighing for a wide range of patients. Convenient keypad tare reduces errors and increases efficiency. Foldable and light, this sturdy scale is easily transported on two heavy-duty rear wheels to any location.

SPECIFICATIONS

Capacity:	360 kg x 0.1 kg
Platform Dimensions:	(W x L x H) 60.96cm x 60.96cm x 6.98cm
Height Rod Dimensions:	77-211 cm Power: 9V DC, provided by six AA alkaline batteries (included) or AC adaptor (optional)
Battery Type:	Six AA alkaline (included)
Battery Use:	25 hours continuous use with batteries Automatic power-off can be configured
Display:	5-digit LCD display, 1.9 mm digit height
Operating Temperature:	14° C to 40° C Warranty: One-year limited warranty

FEATURES

- Dual ramp for on/off access
- Integrated wheels for easy transport
- Large, stable scale base
- Push-button LCD display
- BMI (body mass index) function
- Hold function
- Ability to manually enter the tare weight of additional items, such as a wheelchair or oxygen tank
- Units of measure: lb only, kg only, lb/kg
- Motiontrap™ movement compensation technology
- EHR capable
- Easy to store in closet, folded depth is 29.84cm





Dual-Ramp Wheelchair Scale with Handrail

350-10-3

SHIPPING WEIGHT

	L (CM)	W (CM)	H (CM)	PACKAGE WGT. (KG)	DIM WGT. (KG)	SHIPPING WGT. (KG)
350-10-3	129.54	106.68	35.56	46.26	97.97	97.97
350-10-3BT	127	104.14	33.02	44.45	87.08	87.08

DIGITAL PHYSICIAN SCALE - EYE-LEVEL

MODEL	CAPACITY	COMMUNICATION
350-10-3	(450kg x 0.1kg)	USB
350-10-3BT	(450 kg x 0.1 kg)	USB and Bluetooth 2.0
350-10-3BLE	(450 kg x 0.1 kg)	Bluetooth BLE 4.0

OPTIONS

- 9V DC adaptor, 120 V/230 V auto switching Medical grade power supply
- 9V DC adaptor, 120 V/230V auto switching
- 9V DC adaptor, 230 V
- Tally Roll Printer
- Printer cable, 25-pin D-Sub male to RJ-45, 6 ft

DIMENSIONS

CENTIMETERS

A	123.20
B	81.30
C	6.0
D	23.5
E	96.5
F	114.30

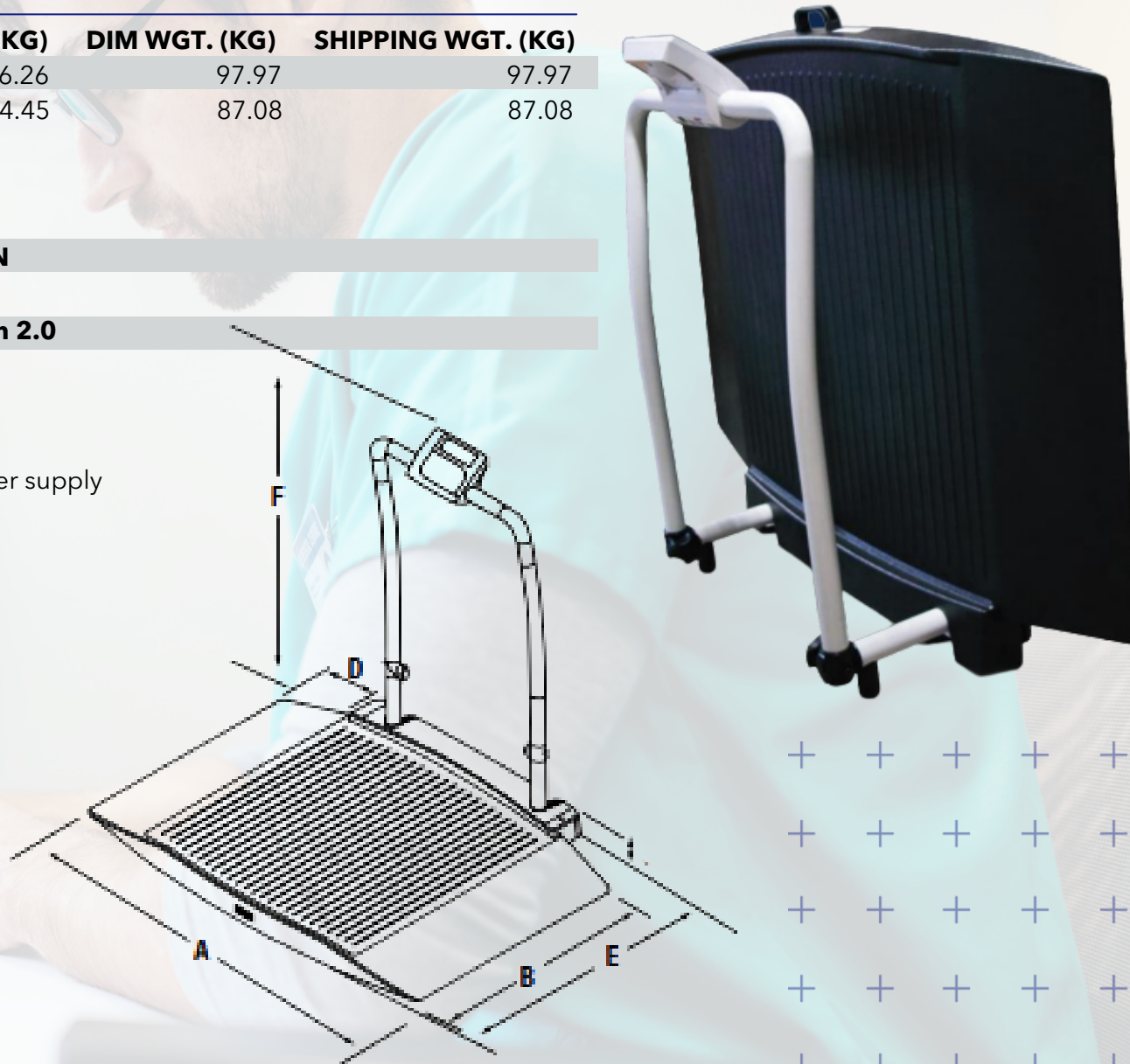



Dual Wheelchair Scale with Seat and Handrail

350-10-4

Rice Lake's 350-10-4 dual-ramp wheelchair scale with seat and handrail allows high capacity, accurate weighing for patients requiring a seat. The padded seat easily tucks away, allowing this model to function as either a wheelchair or chair scale. Convenient keypad tare reduces errors and increases efficiency. Foldable and light, this sturdy scale is easily transported on two heavy-duty rear wheels to any location.

SPECIFICATIONS

Capacity:	450 kg x 0.1 kg
Platform Dimensions:	(W x L x H) 2.54cm x 74.93cm x 6.03cm
Chair Dimensions:	(W x D) 30.48cm x 16.51cm
Display:	5-digit LCD display, 1.9mm digit height
Power:	9V DC, provided by six AA alkaline batteries (included) or AC adaptor (optional)
Battery Type:	Six AA alkaline (included)
Battery Use:	25 hours continuous use with batteries Automatic power-off can be configured
Operating Temperature:	14° C to 40° C
Approvals:	c-Met, E113986
Warranty:	One-year limited warranty

FEATURES

- Dual ramp for on/off access
- Fold-away padded seat with backrest
- Integrated wheels for easy transport
- Push-button LCD display
- BMI (body mass index) function
- Hold function
- Ability to manually enter the tare weight of additional items, such as a wheelchair or oxygen tank
- Units of measure: lb only, kg only, lb/kg
- Motiontrap™ movement compensation technology
- EHR capable





Dual-Ramp Wheelchair Scale with Handrail

350-10-4

SHIPPING WEIGHT

	L (CM)	W (CM)	H (CM)	PACKAGE WGT. (KG)	DIM WGT. (KG)	SHIPPING WGT. (KG)
350-10-4	129.54	109.22	53.34	59.87	150.59	150.59
350-10-4BT	129.54	109.22	53.34	59.87	150.59	150.59
350-10-4BLE	129.54	109.22	53.34	59.87	150.59	150.59

WHEELCHAIR SCALE

MODEL	CAPACITY	COMMUNICATION
350-10-4	(450kg x 0.1kg)	USB
350-10-4BT	(450kg x 0.1kg)	USB and Bluetooth 2.0
350-10-4BLE	(450kg x 0.1kg)	Bluetooth BLE 4.0

OPTIONS

- 9V DC adaptor, 120 V/230 V auto switching c-MET Medical grade power supply
- 9V DC adaptor, 120 V/230V auto switching
- 9V DC adaptor, 230 V
- Epson TM-U220 tape printer
- Printer cable, 25-pin D-Sub male to RJ-45, 6 ft

DIMENSIONS

CENTIMETERS

A	123.20
B	81.30
C	6.0
D	23.5
E	96.5
F	114.30

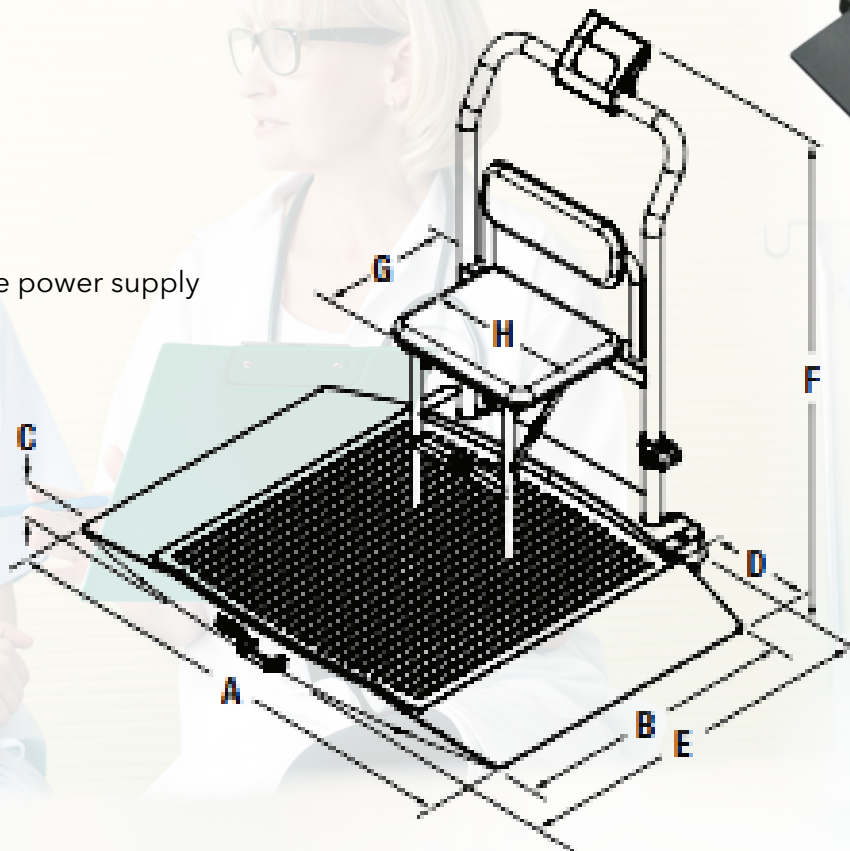

Designed to weigh seated patients. Care and comfort were kept in mind when designing the stable model with a circular steel tube frame. The comfortable seat provides a safe position while the armrests and adjustable footrests make the chair scale more user-friendly. This mobile chair scale, which can be operated by a rechargeable battery provides enormous help in rehab, orthopaedics, dialysis, nursing homes and paediatrics.



SPECIFICATIONS

Capacity:	250kg x 0.1kg
Chair Dimensions:	(W x D) 35cm x 18cm
Display:	Large LCD display unit mounted behind the chair
Power:	Rechargeable Batteries Power Adaptor
Battery Type:	6V 4Ah Lead Acid Rechargeable
Battery Use:	25 hours continuous use with batteries Automatic power-off can be configured
Operating Temperature:	10° C to 50° C
Warranty:	One-year limited warranty

FEATURES

- Ergonomic seat for increased patient comfort
- Robust aluminium construction for a long lifespan
- 100g graduation for accurate measurement while sitting
- Locking mechanism on the wheels to ensure patients can't move during the weighing process
- Adjustable footrests for easy access

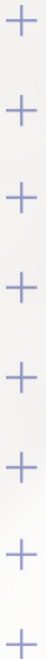



SPARTAN SERIES Wheelchair Scale

SHIPPING WEIGHT

	L (CM)	W (CM)	H (CM)	PACKAGE WGT. (KG)	DIM WGT. (KG)	SHIPPING WGT. (KG)
NWI300-WS	75	87	110	10	143	18

WHEELCHAIR SCALE

MODEL	CAPACITY	COMMUNICATION
NWI300-WS	300kg	N/A

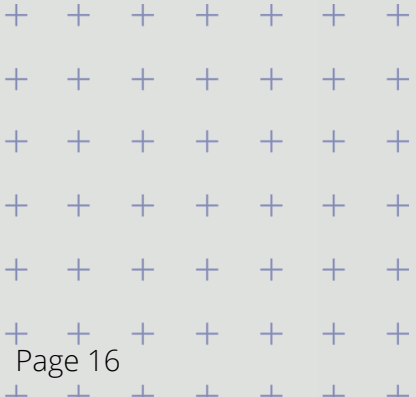



Wireless Wheelchair Scale

D300

The D300 Wireless Wheelchair Scale is lightweight, making it ideal for portable home health providers, yet heavy-duty and durable so it can withstand the repeated weighing requirements of long term care and hospital environments.



Optional transport/carrying case

SPECIFICATIONS

Capacity:	363kg x 0.2kg
Power:	Wheel pads: Eight EL-123 batteries per scale system (two per pad) (included)
Controller:	Three AAA lithium batteries (included)
Battery Type:	EL-123 batteries (included) and AAA lithium batteries (included)
Operating Temperature:	10° C to 32° C
Warranty:	One-year limited warranty

FEATURES

- Four lightweight, wireless scale pads
- Powder-coated molded plastic and cast aluminum construction
- Four wheel-stops and roll-up ramps
- Handheld controller
- Rubber controller glove and lanyard
- Optional carrying case





Wireless Wheelchair Scale D300

SHIPPING WEIGHT

	L (CM)	W (CM)	H (CM)	PACKAGE WGT. (KG)	DIM WGT. (KG)	SHIPPING WGT. (KG)
D300-8	43.18	33.02	33.02	6.8	9.53	9.53

WHEELCHAIR SCALE

MODEL	CAPACITY	COMMUNICATION
350-10-4	(450kg x 0.1kg)	USB
350-10-4BT	(450kg x 0.1kg)	USB and Bluetooth 2.0
350-10-4BLE	(450kg x 0.1kg)	Bluetooth BLE 4.0

OPTIONS

- 9V DC adaptor, 120 V/230 V auto switching c-MET Medical grade power supply
- 9V DC adaptor, 120 V/230V auto switching
- 9V DC adaptor, 230 V
- Epson TM-U220 tape printer
- Printer cable, 25-pin D-Sub male to RJ-45, 6 ft

DIMENSIONS

CENTIMETERS

A	123.20
B	81.30
C	6.0
D	23.5
E	96.5
F	114.30



Wheelchair positioned on pads



Digital Baby Scale

RL-DBS

The RL-DBS digital baby scale accurately weighs and measures even the most active babies. Simply place the baby on the scale, remove the baby and recall its weight by pressing the Recall key. The RL-DBS is portable, extremely durable, and easy to clean and maintain.

SPECIFICATIONS

Capacity:	20 kg x 10 g
Power:	Four AA alkaline batteries (included) or AC adaptor (included)
Battery Type:	Four AA alkaline (included)
Warranty:	One-year limited warranty



Optional carrying case

FEATURES

- Large, easy-to-read one-inch LCD display
- Lb or kg locking capability
- Recall function to view last weight
- Automatic shut-off for long battery life
- Built-in measuring tape (0-57 cm)

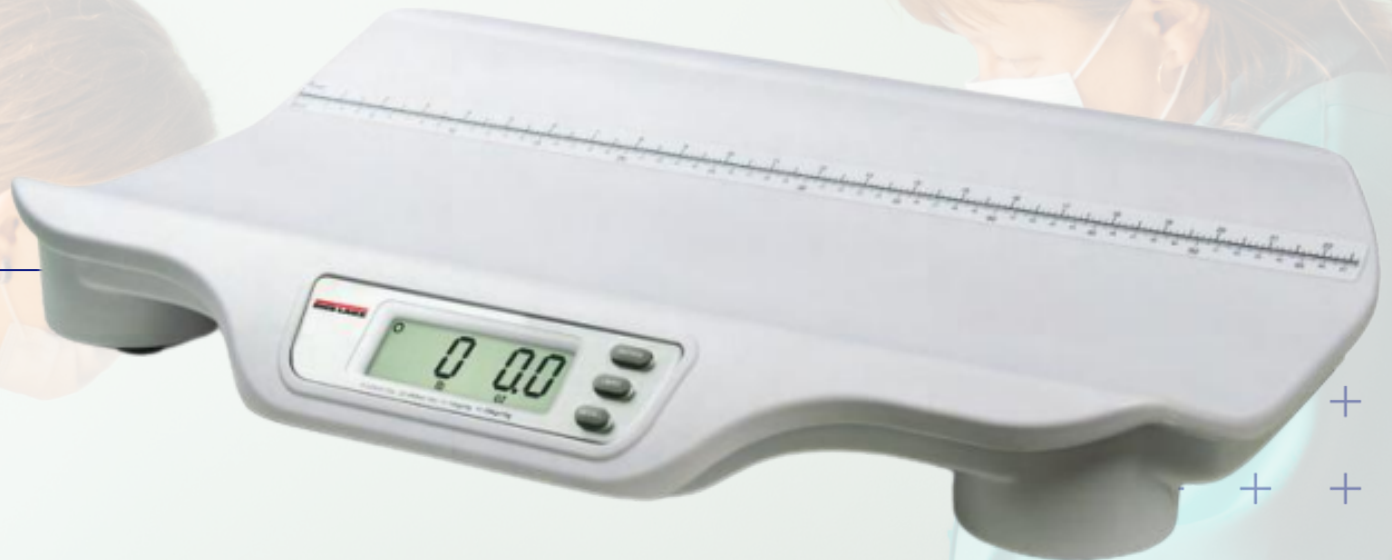



DIMENSIONS

CENTIMETERS

A	9.9
B	38.1
C	7.9
D	60.9
E	27.9

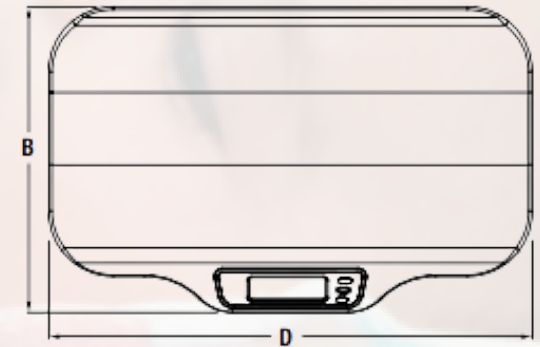
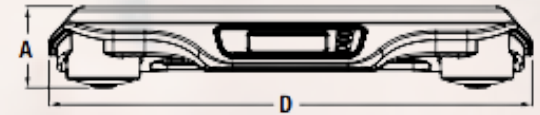
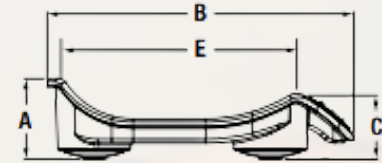

+	+
+	+
+	+
+	+
+	+
+	+
+	+
+	+
+	+
+	+
+	+
+	+
+	+
+	+
+	+
+	+

SHIPPING WEIGHT

	L (CM)	W (CM)	H (CM)	PACKAGE WGT. (KG)	DIM WGT. (KG)	SHIPPING WGT. (KG)
RL-DBS 120V	71.12	45.72	15.24	3.62	9.97	9.97
RL-DBS 230V	68.58	45.72	15.24	4.53	9.52	9.52

DIGITAL BABY SCALE

MODEL	CAPACITY	COMMUNICATION
RL-DBS	(20 kg × 10 g)	120V AC Adaptor
RL-DBS	(20 kg × 10 g)	230V AC Adaptor

OPTIONS

- Carrying case
- Growth chart, birth to 36 months, boy, contains 100 sheets
- Growth chart, birth to 36 months, girl, contains 100 sheets
- Growth chart, 2-20 years, boy, contains 100 sheets
- Growth chart, 2-20 years, girl, contains 100 sheets



Neonatal Dual Scale Range

650-10-1

The 650-10-1 neonatal baby scale precisely weighs even the most active babies up to 33 pounds. Motiontrap™ movement compensation technology compensates for involuntary movements and provides a stable, accurate weight reading. Enhanced precision is essential especially when weighing premature infants. The 650-10-1 provides these precise weighments from zero to 10 pounds with accuracy within 0.05 ounces. A two-sided removable tray keeps babies safe and a built-in measuring tape ensures quick and easy measurements.

FEATURES

- Large, easy-to-read 1.9mm LCD display
- Dual-range capacity for increased precision from 0-10 lb
- Lb or kg locking capability
- Automatic shut-off for long battery life
- Motiontrap™ movement compensation technology
- Built-in measuring tape (0-60 cm x 0.25 cm)

SPECIFICATIONS

Capacity:	0-5 kg x 1 g 5-15 kg x 2 g
Power:	12 VDC, provided by six AA lithium batteries (included) or AC adaptor (optional)
Battery Type:	Six Li-FeS2 batteries
Warranty:	One-year limited warranty
Display:	5-digit LCD display, (1.9 mm) digit height
Operating Temperature:	14° C to 35° C





Neonatal Dual Scale Range

650-10-1

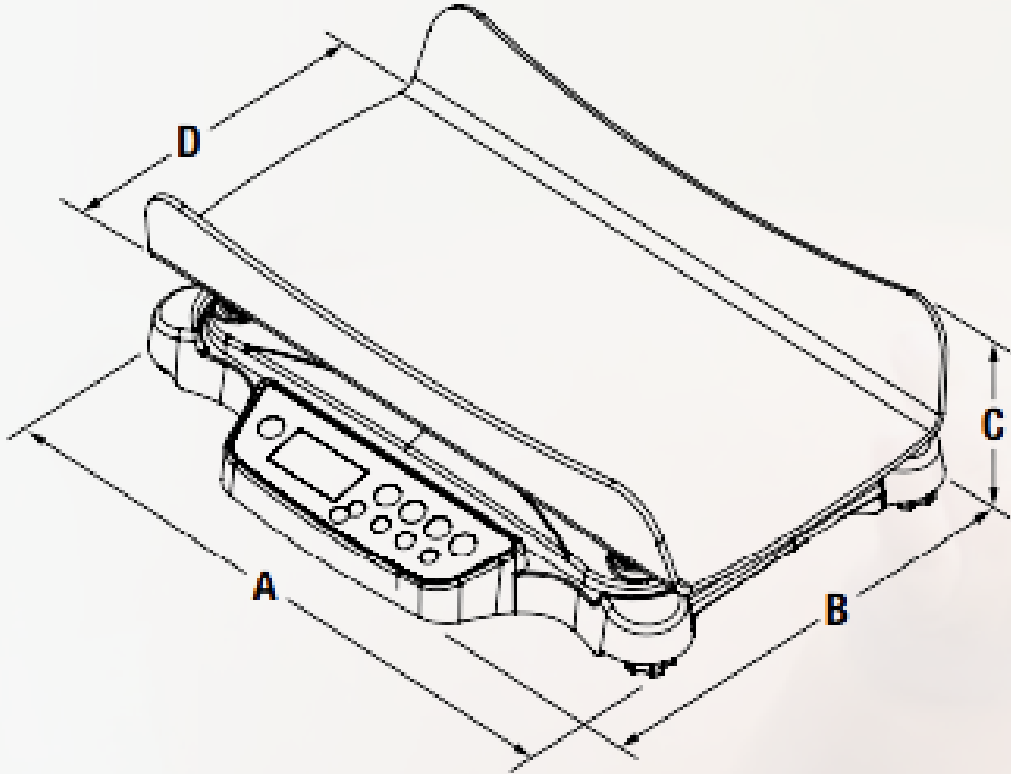

DIMENSIONS

CENTIMETERS

A	60.8
B	48.2
C	17.1
D	43.5

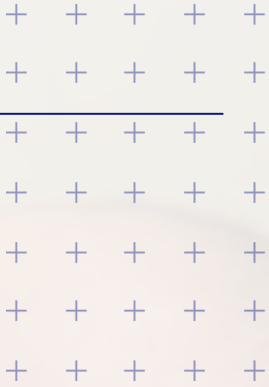

OPTIONS

- AC adaptor, medical grade



SHIPPING WEIGHT

	L (CM)	W (CM)	H (CM)	PACKAGE WGT. (KG)	DIM WGT. (KG)	SHIPPING WGT. (KG)
650-10-1	45.72	71.12	27.94	11.33	18.14	18.14

DIGITAL BABY SCALE

MODEL	CAPACITY	COMMUNICATION
650-10-1	(0-5 kg × 1 g, 5-15 kg × 2 g)	120V/230V



Suspended Infant Scale

OS-10/25/45

The OS-10/OS-25/OS-45 suspended infant scale is a portable device for the safe, accurate weighing of infants and toddlers up to 45 kilograms. Designed for use in any health environment, the OS-10/OS-25/OS 45 suspended infant scale is easily transported and powered by two AA batteries.

Conveniently lift the infant using the sturdy steel s-hook attached to the optional canvas trousers. This paediatric scale is versatile in its applications, and the innovative weighing technique captures vital information safely and accurately

FEATURES

- Hold function
- Units of measure kg/lb/lb-oz
- Adjustable automatic shut-off
- Ergonomic handheld design
- Carrying case and top s-hook included

SPECIFICATIONS

Capacity:	OS-10: 10kg x 0.01kg OS-25: 25kg x 0.02kg OS-45: 45kg x .05kg
Power:	Two AA batteries (included)
Operating Temperature:	0° C to 40° C
Warranty:	One-year limited warranty
Approvals:	CE Marked



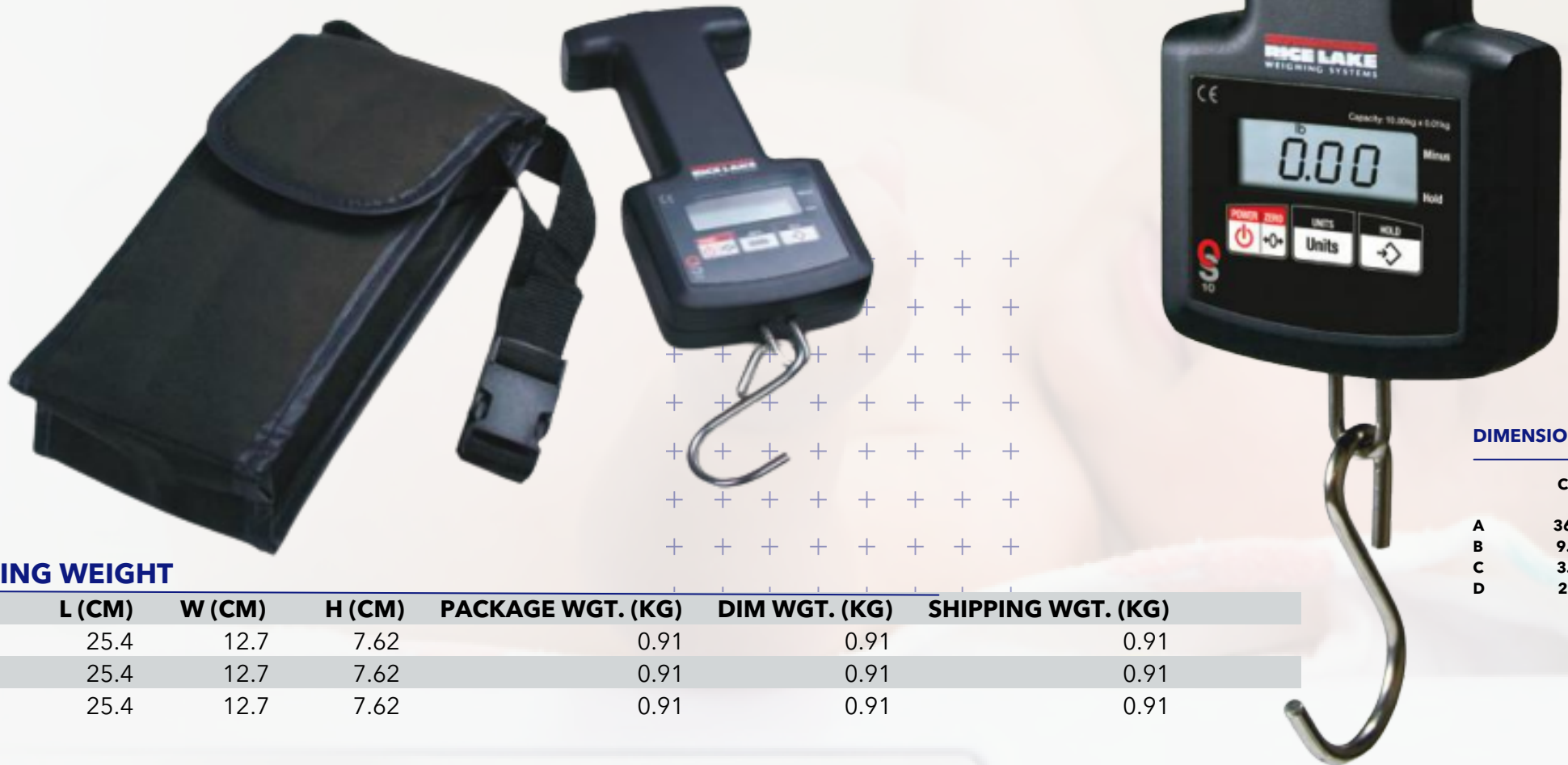

DIMENSIONS

CENTIMETERS

A	36.25
B	9.2
C	3.2
D	29.35

SHIPPING WEIGHT

	L (CM)	W (CM)	H (CM)	PACKAGE WGT. (KG)	DIM WGT. (KG)	SHIPPING WGT. (KG)
OS-10	25.4	12.7	7.62	0.91	0.91	0.91
OS-25	25.4	12.7	7.62	0.91	0.91	0.91
OS-45	25.4	12.7	7.62	0.91	0.91	0.91

SUSPENDED INFANT SCALE

MODEL	CAPACITY	COMMUNICATION
OS-10	(10 kg × 0.01 kg)	AA batteries
OS-25	(25 kg × 0.02 kg)	AA batteries
OS-45	(45 kg × 0.05 kg)	AA batteries

OPTIONS

- Suspended paediatric sling seat trousers

RL-PCT-10 - PAEDIATRIC CIRCUMFERENCE TAPE

- Button to make tape retract around measurement surface for accurate body measurements
- Easy to read measurements, inches on one side centimetres on the other side
- Compact and portable

PAEDIATRIC CIRCUMFERENCE TAPE

MODEL	DESCRIPTION
RL-PCT-10	0-205cm × 1mm

RL-PMM - PAEDIATRIC MEASURING MAT

- Graduations in inches and centimeters along both edges for easy viewing (PN 180124)
- Graduations in centimeters along both edges for easy viewing (PN 182999)
- Washable surface
- Fixed head positioner with sliding foot piece
- Soft, flexible, latex free material
- Head positioner and foot piece designed with rounded edges for safety
- Carry handle and lightweight design for easy portability

PAEDIATRIC MEASURING MAT

MODEL	DESCRIPTION
RL-PMM-10	20cm-99cm measuring range, (5mm) graduation
RL-PMM-20	20cm-99cm measuring range, 5mm graduation



GROWTH CHART - BOY AND GIRL

- Growth chart, birth to 36 months, boy, pack of 100 sheets
- Growth chart, birth to 36 months, girl, pack of 100 sheets
- Growth chart, 2-20 years, boy, pack of 100 sheets
- Growth chart, 2-20 years, girl, pack of 100 sheets

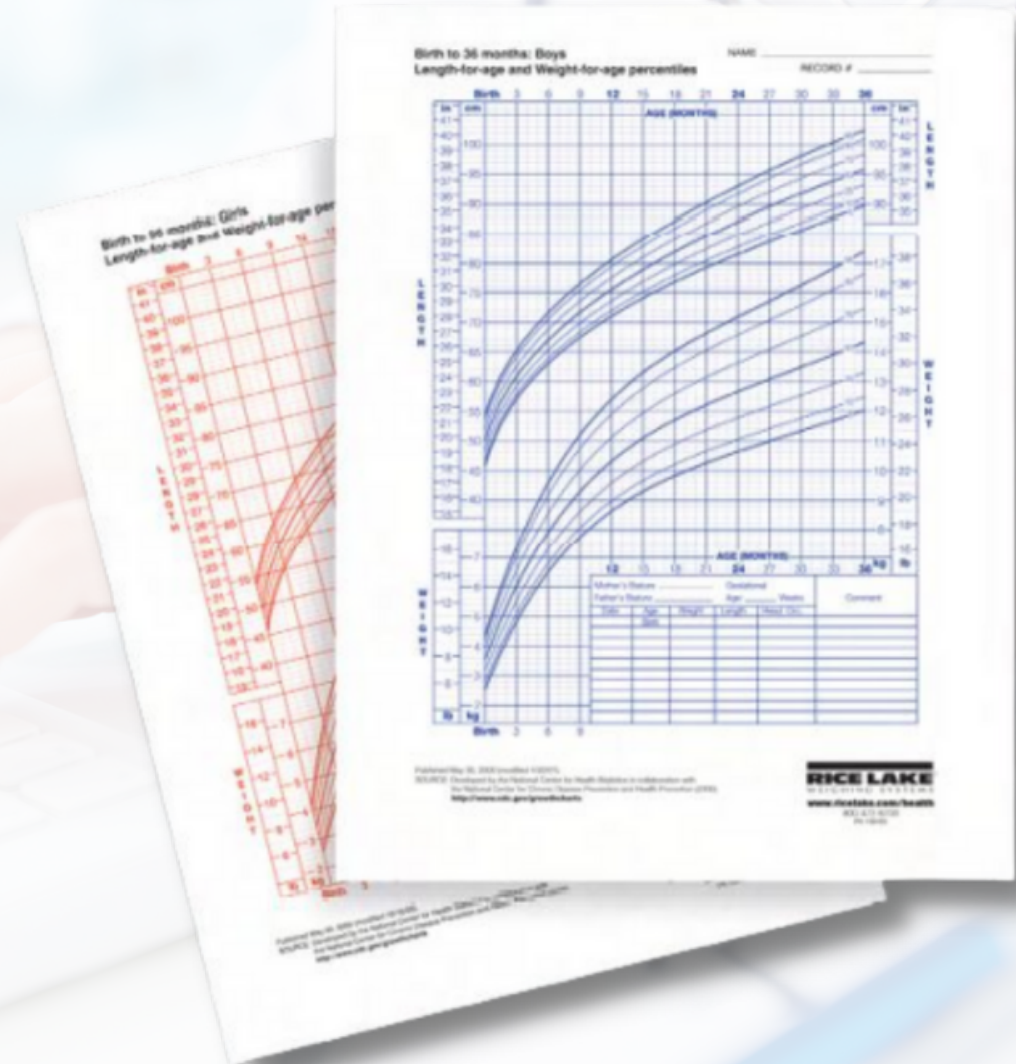
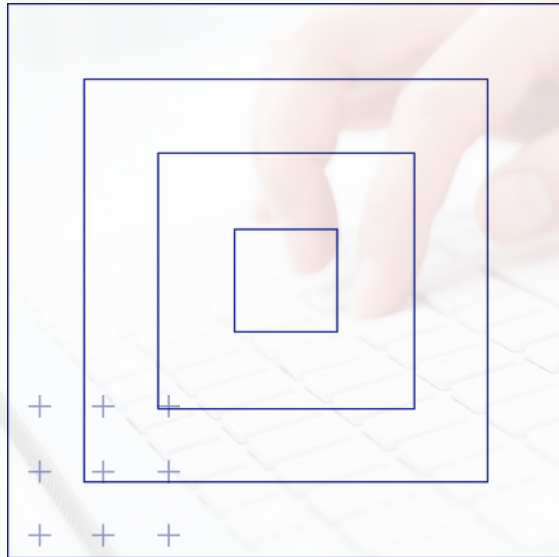



Digital Home Health Scale

RL-440HH

The RL-440HH digital home health scale features the latest digital technology in a sleek professional form. The 1.5 inch, bright LCD display shows weight in pounds, kilograms or stones. The auto hold function continues to show weight value on the display, even after stepping off of the scale. Tap to turn on; it automatically switches off.

FEATURES

- Durable platform with non-slip surface
- Large 1.5 in LCD display
- Tap to turn on - Auto hold keeps weight value on display
- Auto power-off ensures long battery life
- Units of measure: lb, kg, st

SPECIFICATIONS

Capacity:	200 kg x 0.1 kg
Battery Type:	CR-2032 3V Lithium (included)
Warranty:	One-year limited warranty





Digital Home Health Scale

RL-440HH

SHIPPING WEIGHT

	L (CM)	W (CM)	H (CM)	PACKAGE WGT. (KG)	DIM WGT. (KG)	SHIPPING WGT. (KG)
RL-440HH	38.1	38.1	10.16	10.16	3.17	3.17

DIGITAL HOME HEALTH SCALE

MODEL	CAPACITY
RL-440HH	(200kg x 0.1kg)

DIMENSIONS

	CENTIMETERS
A	32.8
B	34.8
C	4.1

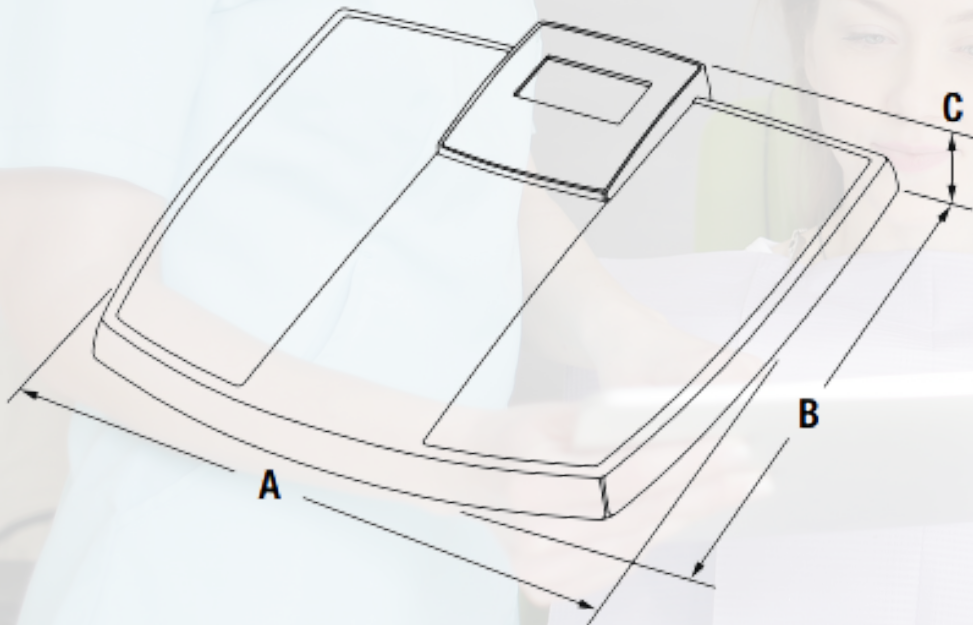



Digital Home Health Scale

DHH-10

The RL-440HH digital home health scale features the latest digital technology in a sleek professional form. The 1.5 inch, bright LCD display shows weight in pounds, kilograms or stones. The auto hold function continues to show weight value on the display, even after stepping off of the scale. Tap to turn on; it automatically switches off.

FEATURES

- 8mm tempered safety glass weighing surface
- Battery operation
- Low battery indication
- Display lb or kg with the simple press of a button
- Large LCD display

SPECIFICATIONS

Master Carton:	(2) scales contained in each master carton
Capacity:	200 kg x 0.1 kg
Battery Type:	(2) AAA alkaline batteries (included)
DHH-10BT:	Designed to work with AccuroFit App available for Apple and Android
Warranty:	One-year limited warranty





Digital Home Health Scale

DHH-10

SHIPPING WEIGHT

	L (CM)	W (CM)	H (CM)	PACKAGE WGT. (KG)	DIM WGT. (KG)	SHIPPING WGT. (KG)
DHH-10	45.72	38.1	10.16	5.98	3.53	5.89 DHH-
10BT	45.72	38.1	10.16	5.98	3.53	5.89



DIGITAL HOME HEALTH SCALE

MODEL	CAPACITY
DHH-10	(200 kg x 0.1 kg)
DHH-10BT	(200 kg x 0.1 kg) with Bluetooth

DIMENSIONS

	CENTIMETERS
A	39
B	30
C	2.5

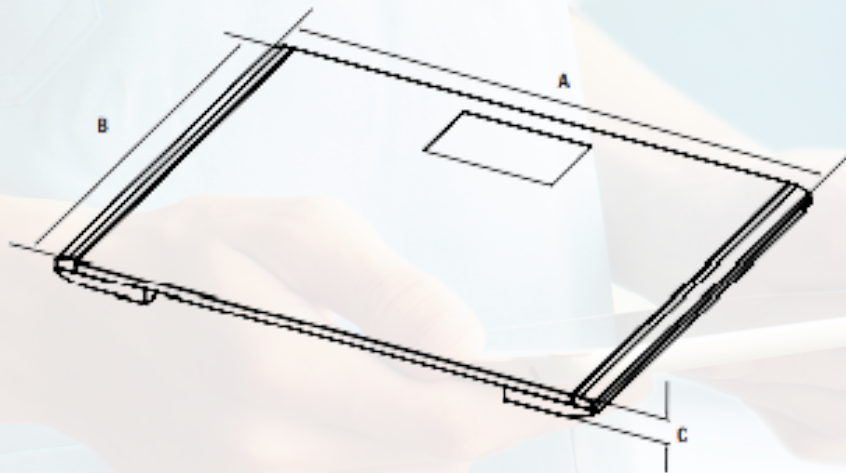

NWI Group is committed to ensuring our customers instruments are calibrated and meet all manufacturers specifications and industry regulations. Our specialist service and calibration technicians collectively have decades of experience in calibrating all types of weighing, process instrumentation, analytical and laboratory equipment.

We provide both on-site and laboratory calibrations for 100's of different types of instruments for 1000's of different manufacturers.

Our capabilities extend to the following:

PATHOLOGY

- Scales*
- Balances*
- Masses*
- Thermometers*
- Data loggers*
- Medical Refrigeration*
- Microscopes
- Centrifuges*
- POVA*
- PCR Machines
- Incubators*
- Timers*
- Dry Block Heaters

PATIENT WARDS

- Scales*
- Balances*
- Thermometers*
- Fridges, Freezers & Cool Rooms*
- Vaccine Fridges*

KITCHEN

- Scales*
- Thermometers (Stab Probes)*
- Refrigerators, Cool Rooms & Freezers*
- Timers*

BIOMEDICAL

- Electrical - Clamp Meters, Multi-Meters and Appliance Testers*
- Temperature*
- Pressure
- Masses*
- Scales & Balances*

NOTE: Items with an asterisk next to them can be calibrated with a NATA Certification





NWI
GROUP



**Weighing
Instrumentation
Systems
Fabrication
Calibration**

World-class precision, locally delivered.

Sydney | Melbourne | Adelaide | Brisbane | Perth

nwigroup.com.au

1300 669 162