

# DD700i - DD700ic

## Intelligence Series

### DESK AND WALL MOUNT INDICATOR/CONTROLLER



## Intelligence Made Easy

Designed for the ease of use yet with the power to deliver your weighing process, Bilanciai's DD700i-ic Intelligence Series indicators/controllers are packed power, innovation, and performance with multi communication channels, yet are simple and easy to operate.

The intuitive multifunction keyboard allows for ease of use within any of the standard software applications available or connect an industrial USB keyboard for fast data entry and control. Versatile connectivity with the power to interface to Analogue or Digital loadcells complete with detailed intuitive on board Diagnostics and error logging tools.

The responsive high speed converter card coupled with configurable DIGITAL FIR filtering makes the weighing process fast, controlled and responsive.

With standard Checkweighing, TakeAway, Single weighing, Sum weighing, Parts Counting, Grading, Multi-Operator software, Batching (loading/unloading extraction) with Fall and inflight calculation, Display function "Hotkeys", customisable display messages and print layouts, a host of standard printer interfaces and data download via the USB or ethernet the DD700i-ic is industry ready.



DD700i IP69K VERSION

Cable entries for mains power, scale connection, comms and options cards via stainless steel glands.

### INTELLIGENT STABILITY

Fully configurable DIGITAL FIR filtering and update speeds allow you to tailor your DD700i-ic to suit your application, giving you fast and accurate weighing results whatever the environmental conditions. You can be confident that the data provided and the outputs controlled will exceed your expectations.

### INTELLIGENT COMMUNICATION

The standard communication interfaces of the DD700i-ic Series indicators deliver an industry leading variety of connectivity options out classing its contemporaries. 2xRS232-1xRS422-1xRS485, 1xUSB-Host, 1xUSB-Client, 2xInput/Outputs, option cards 4-20mA or 0-10V Analog output, up to 8x Inputs - 8x Outputs, TCP/IP 10/100 Mbps; Profibus DP and Wifi adds even more communication capacity.

### INTELLIGENT STRENGTH

The D700i-ic Series are designed for industry and built to last.

- Advanced FIR Averaging Digital filtering
- 10,000 Divisions NTEP and 2 x ranges 4,000 Divisions or 3 x ranges 3000 Divisions OIML approved
- Connect up to 24 x 700 Ohm analogue or 12 x Digital loadcells
- Powered by an Internal "i"  
- External "ic" 110-240 Vac 50-60 Hz power supply
- DD700i - IP69k Stainless Steel enclosure endures harsh environment

## CATEGORY



# DESK AND WALL MOUNT INDICATOR/CONTROLLER

## DD700I-IC SERIES

With Desk, wall and column mount versions available, the DD700i IP69k indicator is designed for the harshest of environments where fast and reliable weighments are required.

An optional "checkweighing" multi coloured bar graph provides a fast visual guide to the weighing operation, whilst data can be downloaded via network, WiFi or by the IP69k USB interface.

The DD700ic industrial terminal is designed for easy access to all the interface and scale connectors whilst providing industrial robustness and protection to the electronic components.

The DD700i-ic indicators deliver all of the powerful features you expect from leaders in their class with industrial styling the DD700i-ic not only perform in the harshest of environments they are designed to last, the alphanumeric keypad or an optional industrial USB keyboard, simplifies the user experience, making operations more convenient and flexible.

## INTELLIGENT FLEXIBILITY

With customizable Display "HOTKEYS", Display messages, Display Data, Print layouts, Checkweighing, TakeAway, Single weighing, Sum weighing, Parts Counting, Grading, Multi-Operator software, Batching (loading/unloading extraction) with Fall and inflight calculation and configurable setpoint control the DD700i-ic are the most flexible terminals in their class.

- Selectable multipoint setpoint operations
- "HOTKEY" preference ordering on the display
- Rename "HOTKEYS" to suit your application
- Multilingual setup with English, Spanish, German, French, Portuguese and Italian as standard



DD700i-ic INDUSTRIAL VERSION

## INTELLIGENT PERFORMANCE

The DD700i-ic Series can be easily adapted to your application, with configurable data memory and databases, backup & restore features, data export & Import via CSV files, Intelligence is made easy

- Configurable dynamic memory storage capacity for Truck ID, Product, Client, Plate, Operator databases
- Alphanumeric data entry descriptions for all available databases
- Export and import data in standard CSV format
- Totalise by Partial, General, Product, Plate or Client Codes
- Configurable as Master or Slave display
- Traffic light sequencing interface control
- Multiple Printer drivers and peripherals interfaces (Scanners, RFID)



# INTELLIGENCE SERIES - DD700i-ic INDICATOR

## STANDARD FEATURES

- Backlit graphic display, dimensions 135x32 mm
- 1 x RS232 Serial Port
- 1 x RS232/RS422/RS485, 240x64 pixel
- 1 x USB Host - 1 x USB Client
- 2 x Inputs - 2 x Outputs
- Power supply - Internal "i" - External "ic", 110-240 Vac 50-60 Hz,
- DD700i - IP69k Stainless Steel enclosure
- DD700ic - Stainless Steel enclosure with open connectors
- Flat membrane 18 key Alphanumeric keyboard
- Calendar clock
- Audit trail tracking for configuration and calibration changes
- FIR Digital filter settings
- Max 12 x 350 ohm Analog loadcells 5V powered
- Max 12 x Digital loadcells
- NTEP 10.000 divs approved
- OIML 2 ranges 4000 divs approved, 3 ranges of 3000 divs
- Single weighing - Sum Weighing
- Checkweighing & TakeAway operation
- Batch weighing operation,
- Multi Operator - Grading - Parts Counting
- Double weighing
- Customisable ticket formats
- Customisable display "Hot Keys" and descriptions
- Customisable display messages
- Multiple industrial printer drivers

## OPTIONS

- AVAILABLE FOR TWO OPTION SLOTS -

- Analog output, 0-10 VDC, 4-20 mA
  - Profibus DP
  - Ethernet/IP
  - Ethernet port TCP/IP(10/100Mbps)
  - WIFI (External)
  - 4 inputs / 4 outputs optically isolated 24 VDC 200mA
  - MPP Alibi memory
  - Coloured Bar Graph for DD700i Checkweigher display
- 
- Desk mount bracket for DD700i
  - Wall bracket for DD700ic
  - Possible to install on a column mount

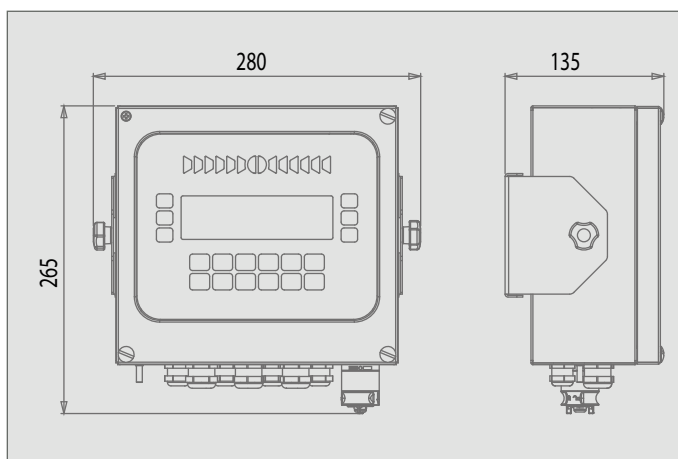

DD700i - WALL MOUNT VERSION

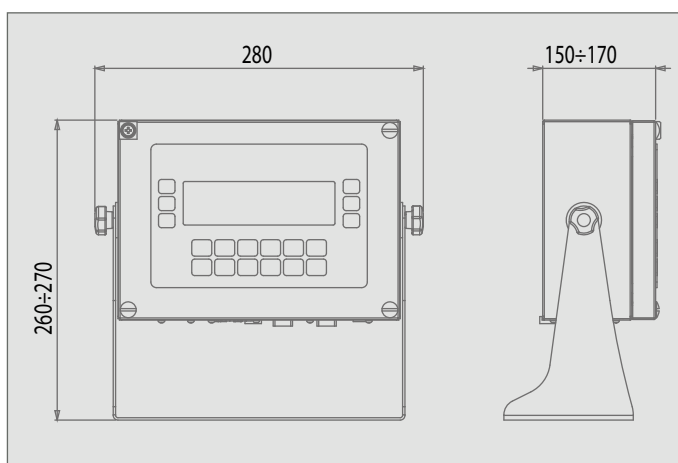

DD700ic - DESKTOP VERSION

