

# DFW • DFWL

TECHNICAL MANUAL

ENGLISH

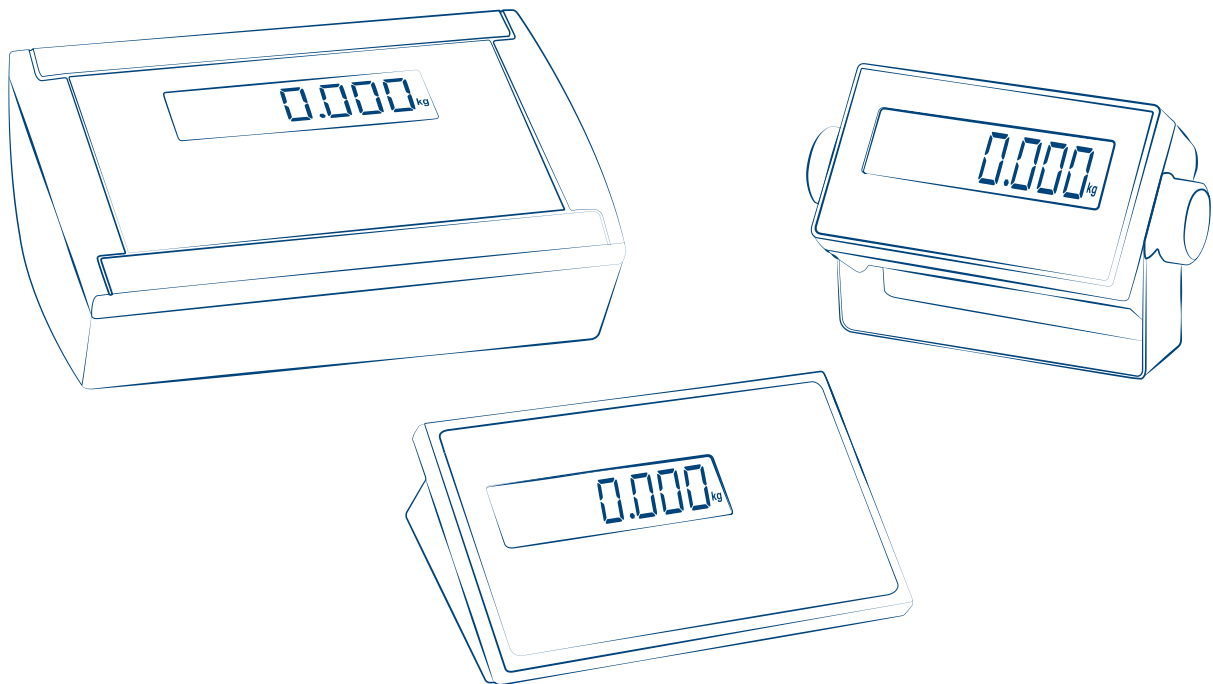



<b>1. Introduction and warnings</b> .....	<b>4</b>
<b>2. Technical features</b> .....	<b>4</b>
<b>3. Approval</b> .....	<b>5</b>
<b>4. Connections</b> .....	<b>6</b>
Single channel .....	6
Multichannel.....	7
<b>5. Programming</b> .....	<b>8</b>
How to access the programming menu.....	8
How to save the programming and exit the menu .....	8
Programming menu .....	9
<b>6. Communication strings</b> .....	<b>42</b>
<b>7. Communication controls</b> .....	<b>43</b>
<b>8. Wiring schemes</b> .....	<b>45</b>
DFWLxxx, WLB, TPWNxxx, TPWLxxx, MCWNxxx.....	45
DFWLIDxxx.....	45
DFWxxx, TPWxxx, MCWxxx.....	46
RS232 serial port with RJ11 connector .....	46
<b>9. Programming errors</b> .....	<b>47</b>
<b>10. Summary of the parameters</b> .....	<b>48</b>
<b>11. FAQ - Frequently Asked Questions</b> .....	<b>50</b>

## CONTENTS BY TOPIC

### Calibration

Quick calibration .....	10
<u>Complete calibration .....</u>	<u>38</u>

### Equalisation

Multichannel connection .....	7
Equalisation procedure.....	37

### Safety

Protection of the configuration menu via PIN.....	41
Protection of the user menu via PIN .....	41

### Communication

Configuration of the serial port for PC.....	12
Configuration of the serial port for printer .....	14
Wiring schemes.....	45
Communication strings.....	42
Communication controls .....	43

### Approval

Approval seal.....	5
Display of the metrological version .....	5

### Reset

Factory configuration reset .....	34
Complete reset of memory .....	41

# 1. INTRODUCTION AND WARNINGS

This product represents the best solution for multi-function weighing applications, offering ease of use, high precision in reading the weight and many functions to speed-up and simplify everyday work.

This manual provides an overview of the product's potentials: through the configuration menu, you can adapt the product functionality to the weighing application to be realised.



## WARNINGS:

- Do not make repairs or replace electronic components of the instrument boards.
- Only use original spare parts.
- Any tampering with the equipment or use of non-original spare parts voids the warranty and relieves the manufacturer of any liability.
- Before any installation or repair that involves access to electronic parts, turn off the device and disconnect any source of power supply (battery, 230V network or other).
- Always use network power supply sources regulated within  $\pm 10\%$  of the rated voltage;
- In applications in connection with third parties, always follow the specifications given on the approval decree of the equipment.
- Do not immerse in water.
- Do not wash with water jets (except versions with specific IP protection degree).
- Protect from direct rainfall (except versions with specific IP protection degree).
- Do not use aggressive cleaning solvents or substances.
- Do not install in potentially explosive environments.
- Earth connect any earth socket located on the equipment casing, using a cable with a diameter of at least 16 mm<sup>2</sup>.

# 2. TECHNICAL FEATURES

Power supply via mains / Battery charger	110-230Vac	
MAX consumption	5W	
Analog channels for reading of load cells	4	
Managed / displayed scales	1	
Connectable cells	8 da 350 Ohm	
Load cells power supply	5V	
Maximum load cells power supply current	120mA	
Maximum operating temperature range CE-M - OIML	-10°C + 40°C	
Maximum operating temperature range	-10°C + 60°C LCD/-20°C + 60°C LED	
OIML divisions	10000e 3x3000e	
Divisions for internal use	100d ... 1.000.000d	
Optional Digital relays (only for DFW family)	Number	2 / 4
	Features	48 Vac, 60 Vdc, 15 mA, 10 $\Omega$ Max
Optional Digital inputs (only for DFW family)	Number	2 / 4
	Features	12 / 24 Vdc, 5:20 mA
Optional analog output (only for DFW family)	0:10 Vdc, 0:20 mA	
Serial ports	2	

# 3. APPROVAL

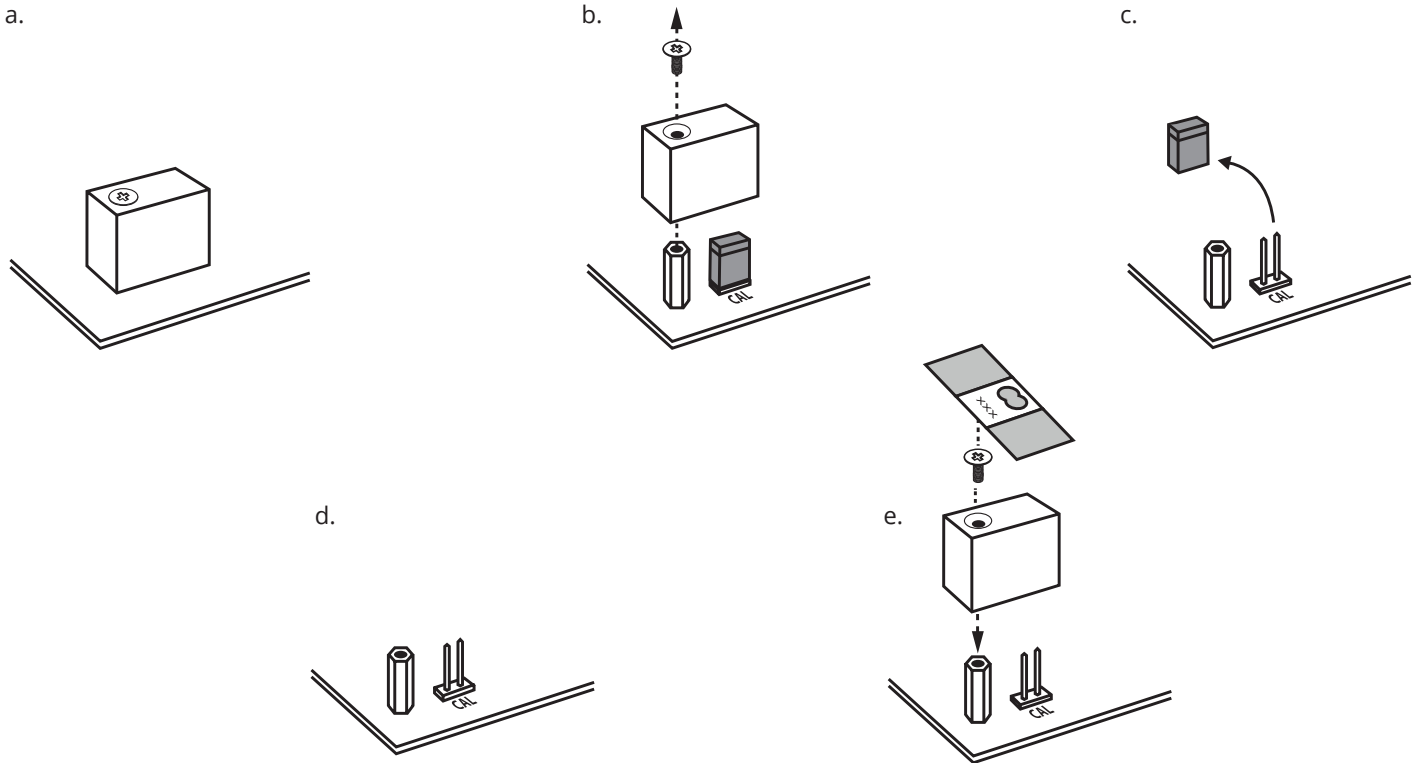

## How to display the metrological version of the instrument



### 1. Turn off the scale

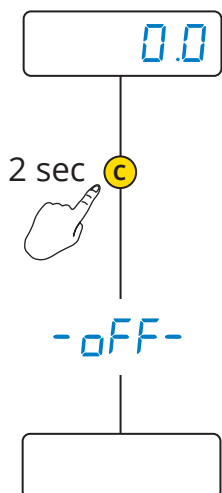

### 2. Follow the procedure:

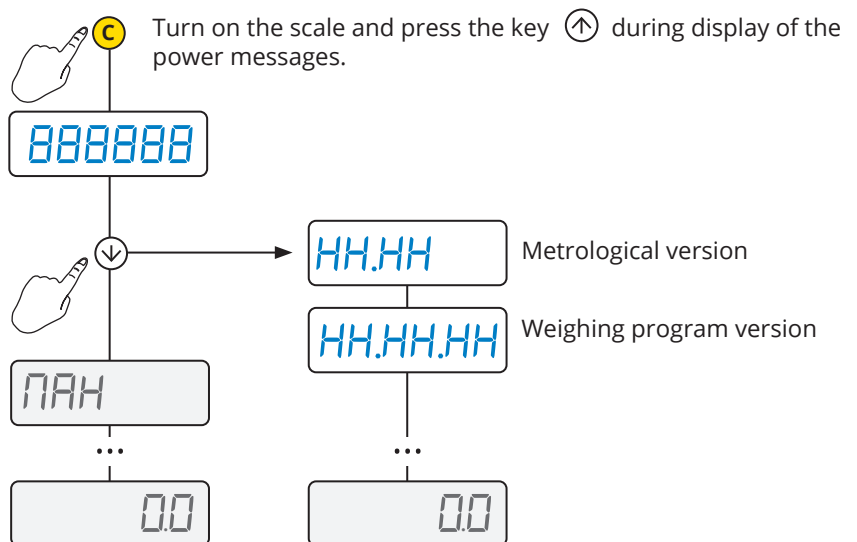

# 4. CONNECTIONS

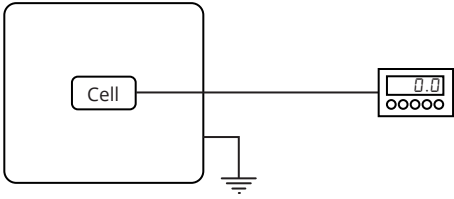

## Single channel



Connect the scale to the main terminal board using the first reading channel of the A/D converter.

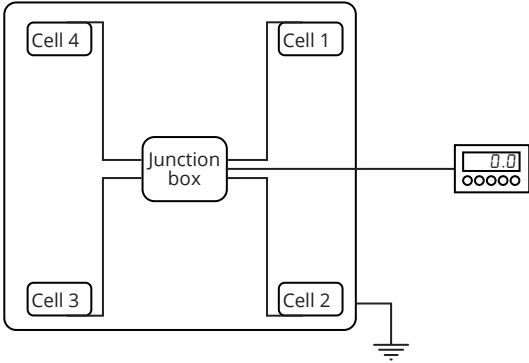

## Terminal board of reference for connection to 1 channel

### NOTES:

- For connection with 6 wires with "Sense", remove jumpers J2 and J3.
- For connection with 4 wires, install jumpers J2 and J3.



### WARNING:

Make the connections with indicator off and feeder disconnected. Comply with the electronic specifications indicated in the table on page 4

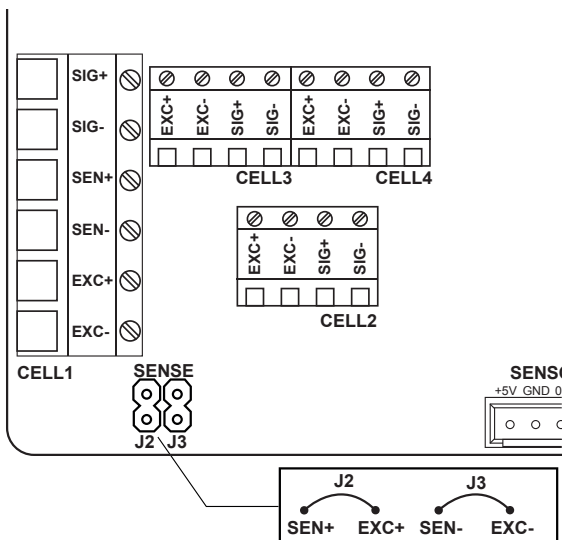

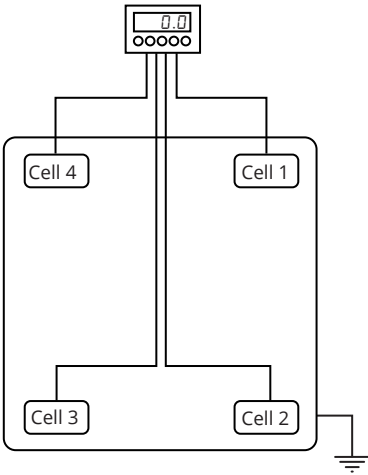

## Multichannel with digital equalisation



You can use the 4 channels of the converter to connect 2, 3 or 4 cells, digitally equalising them without using junction boxes.

## Terminal boards of reference for connection to 4 channels

### NOTES:

- Install jumpers J2 and J3.

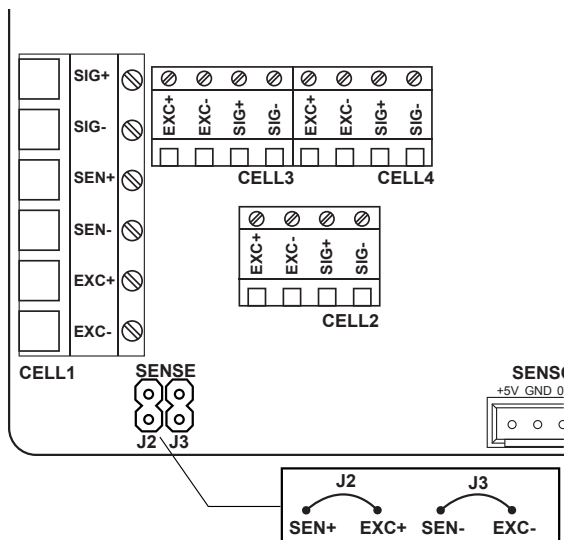

# 5. PROGRAMMING

## How to access the programming menu



### 1. Turn off the scale

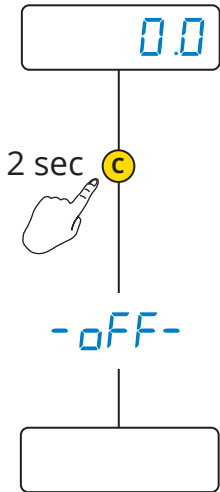

### 2. Follow the procedure:

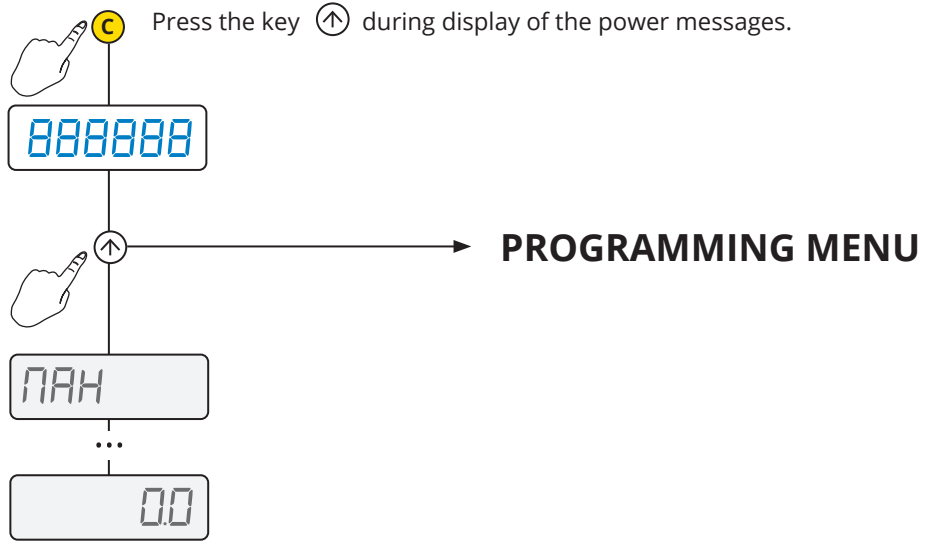

## How to save the programming and exit the menu



To save the programming changes made, repeatedly press the key **C** browsing the menu in reverse, until the message **SAVEP** appears: press **←** to save or **C** to exit without saving.

Example (read from right to left):

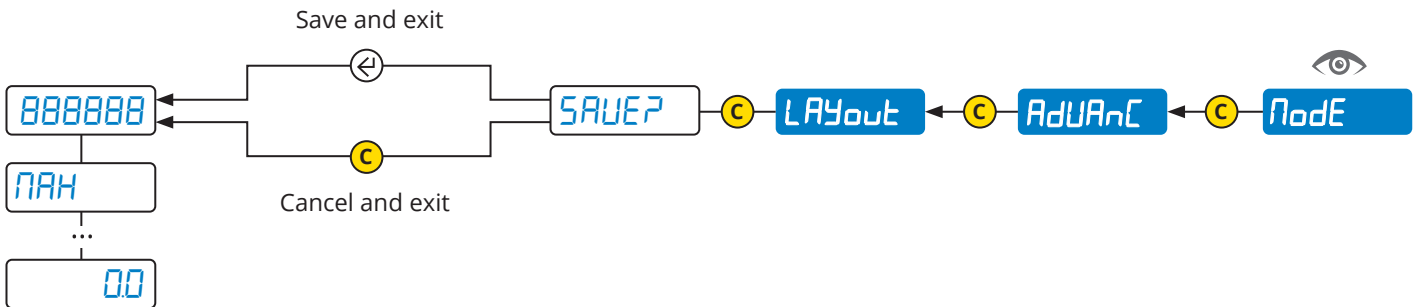



## ⚙️ PROGRAMMING MENU

	CAL	Quick calibration.....	10
↓			
	DCAL	Reset of Pre-Tare (zero calibration).....	11
↓			
	GrAV	Area of gravity of the place of use.....	11
↓			
	SErIAL	Configuration of the serial ports.....	12
↓			
	LAYout	Print customisation.....	18
↓			
	FILTEr	Weighing filter.....	26
↓			
	SCrEEen	Adjusting the display.....	27
↓			
	bAtt	Using the battery.....	28
↓			
 			
↓	ECo.bAtt	Energy saving.....	28
↓			
	AutoFF	Auto off.....	29
↓			
	rENotE	Using the remote control.....	29
↓			
	An.out	Analog output.....	30
↓			
	inPutS	Digital inputs.....	32
↓			
	outPut	Digital outputs.....	33
↓			
	rESEt	Factory configuration reset.....	34
↓			
	dIAG	Diagnostics.....	34
↓			
	AdVAnC	Advanced.....	35

### How to enter

- Off
- On
- 

Page 8

### How to browse

- =
- =
- =
- =

### How to save and exit



Page 8

- A **CAL**
- B 0.CAL
- C GrAU
- D SEr iAL
- E LAYout
- F iLteR
- G SCrEEen
- H bAtte
- I ECo.bAt
- J AutoFF
- K rENotE
- L An.out
- M inPutS
- N outPut
- O rESEt
- P d iAG
- Q AdVAnC



Start of the calibration procedure:

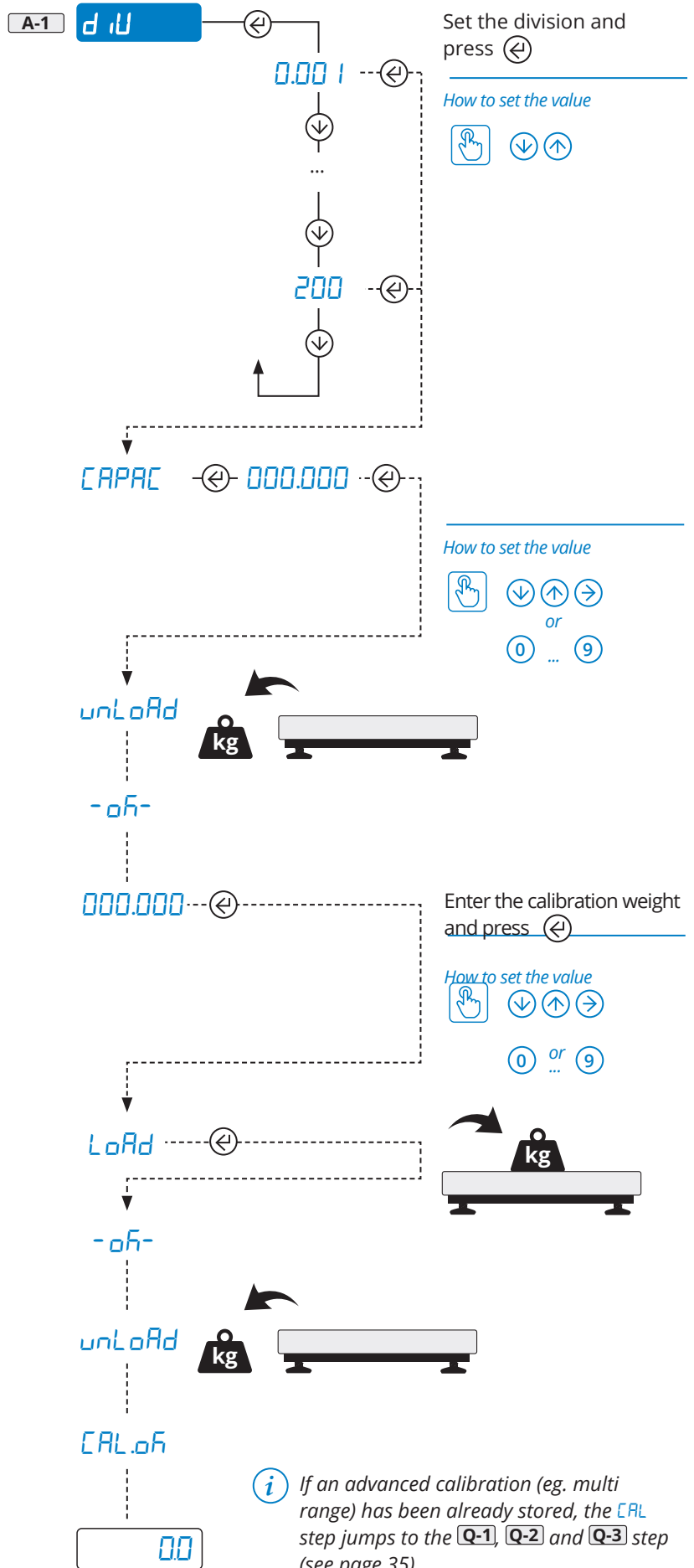

# MENU

How to enter

1. Off
2. On
- 3.

Page 8

How to browse

- =
- =
- =
- =

How to save and exit



Page 8

- A CAL
- B **O.CAL**
- C **GrAU**
- D SEr iAL
- E LAYout
- F iLteR
- G SCrEEen
- H bAtte
- I ECo.bAt
- J AutoFF
- K rENotE
- L An.out
- M inPutS
- N outPut
- O rESEt
- P d iAG
- Q AdVAnC

## O.CAL Reset of the Pre-Tare



Acquisition of the zero point

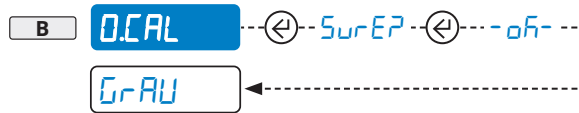

## GrAU Area of gravity of the place of use



Once the calibration is completed, for proper operation set the area of use in this pitch (if different from that of calibration).



How to set the value

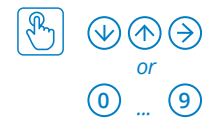

How to enter

1. Off
2. On
- 3.

Page 8

How to browse

- =
- =
- =
- =

How to save and exit



Page 8

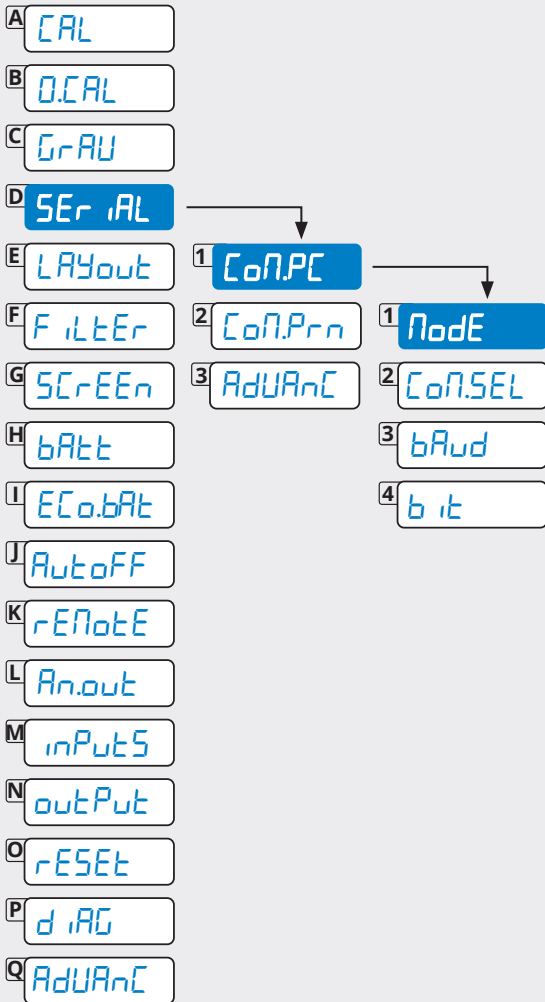

**CoN.PC** Communication with PC, PLC or Repeater

Selection of the communication mode

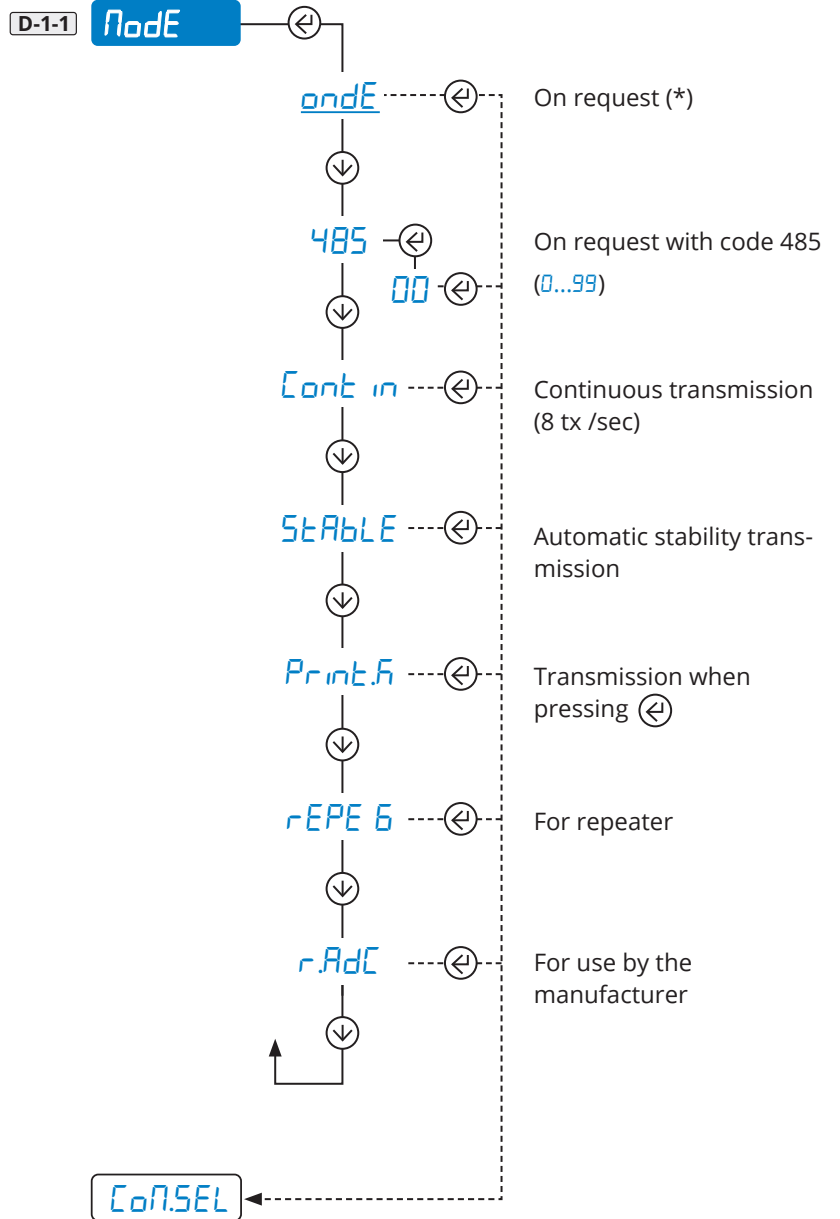

\* For communication strings and controls, see page 42 - 43.

For the string selection, see step **D-3-1**.

# MENU

How to enter

1. Off
2. On
- 3.

Page 8

How to browse

- =
- =
- =
- =

How to save and exit



Page 8

A CAL

B D.CAL

C GrAU

D SEr iAL

E LAYout

F FiLteEr

G SCrEEEn

H bAtte

I ECo.bAt

J Autoff

K rENotE

L An.out

M inPutS

N outPut

O rESEt

P d iAG

Q AdVAnC

1 CoN.PC

2 CoN.Prn

3 AdVAnC

1 Node

2 CoN.SEL

3 bAud

4 b it

Selecting the COM port for connection with PC/PLC

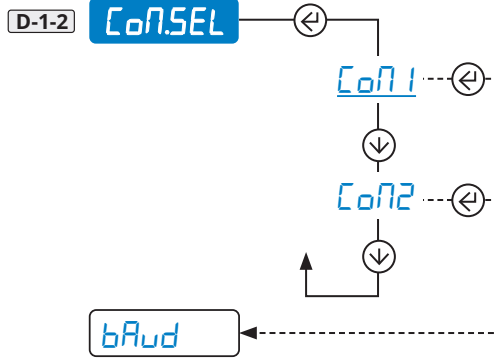

Communication speed (Baud rate)

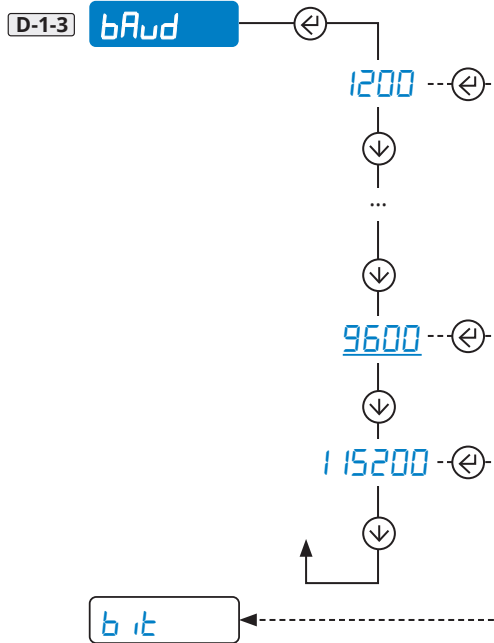

Configuration of the serial protocol

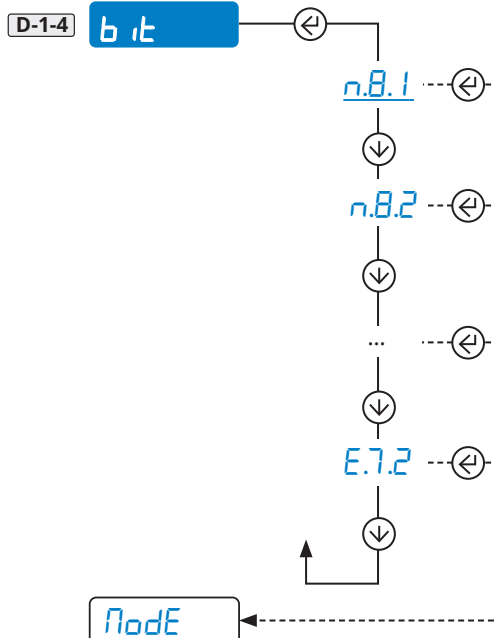









How to enter

- 1. Off 
- 2. On 
- 3. 

 Page 8

How to browse

-  = 
-  = 
-  = 
-  = 

How to save and exit



 Page 8

**CoNPrn** Communication with printer or repeater or PC 

Selection of the communication mode

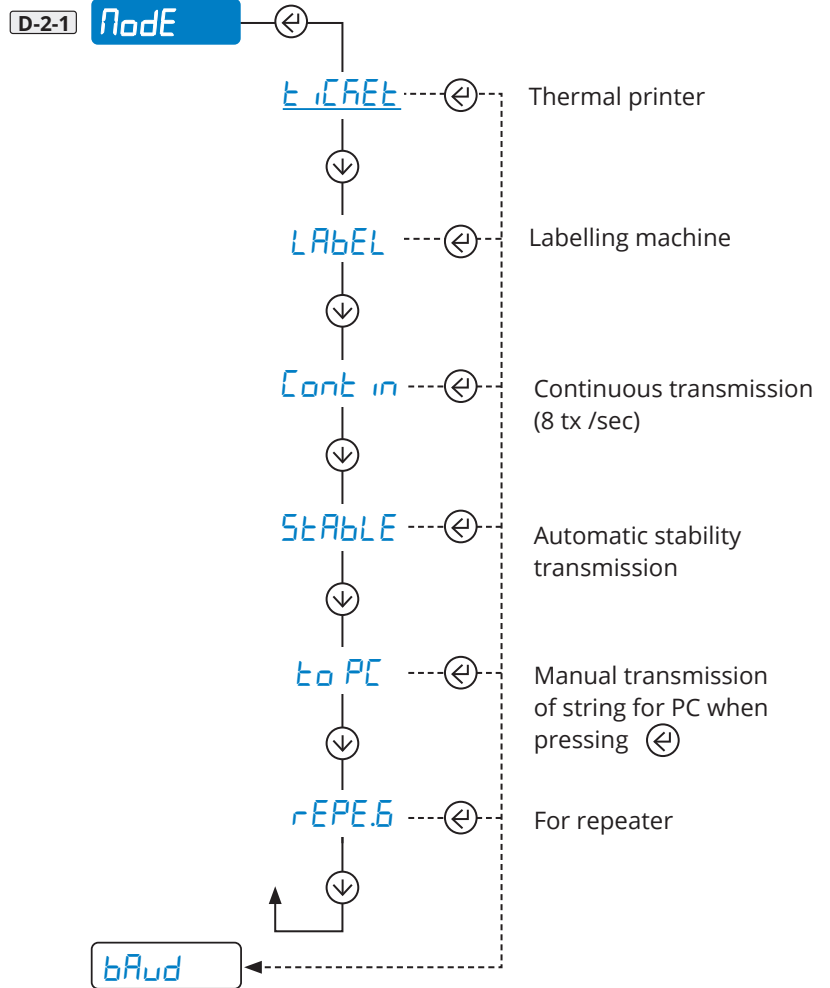
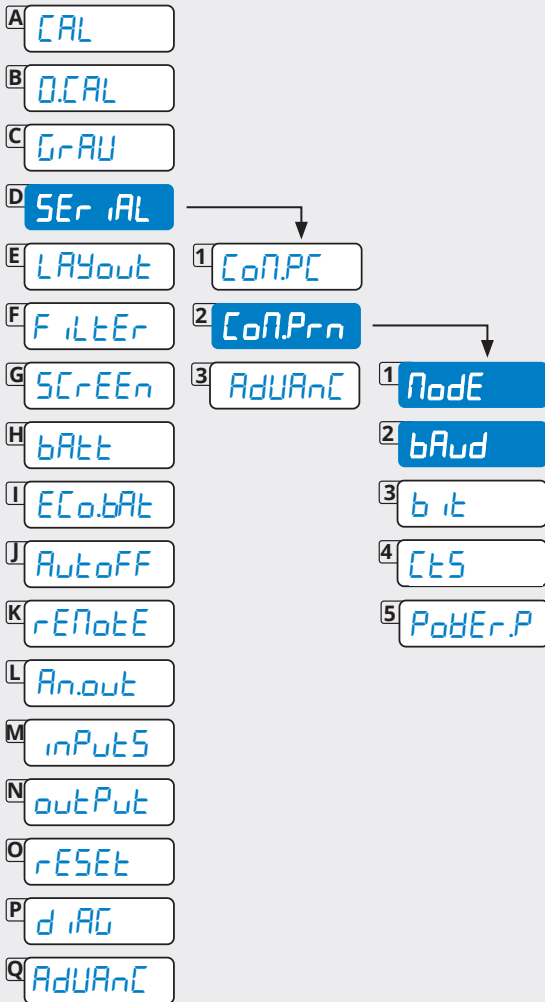

 For communication strings and controls, see page 42 - 43.

Communication speed (Baud rate)

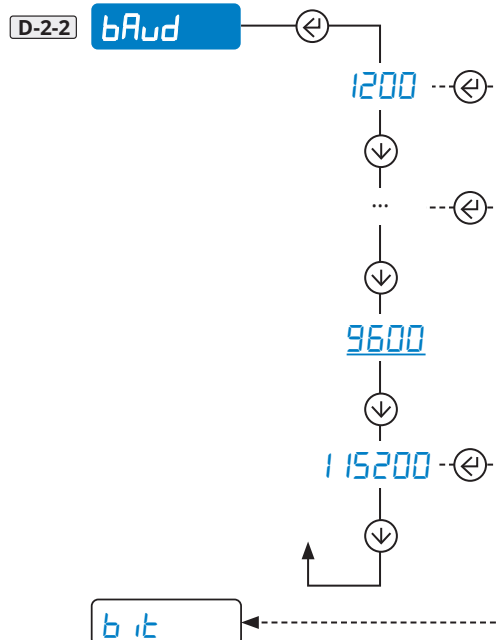

# MENU

## How to enter

1. Off
2. On
- 3.

Page 8

## How to browse

- =
- =
- =
- =

## How to save and exit



Page 8

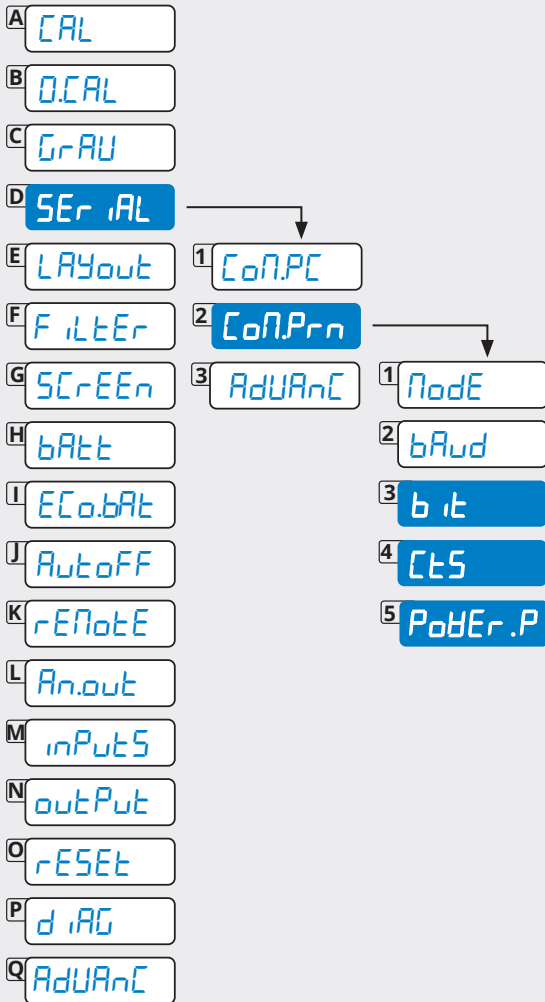

## Configuration of the serial protocol

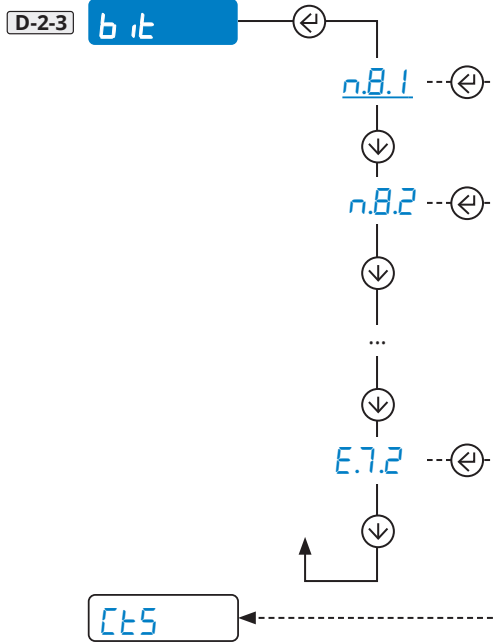

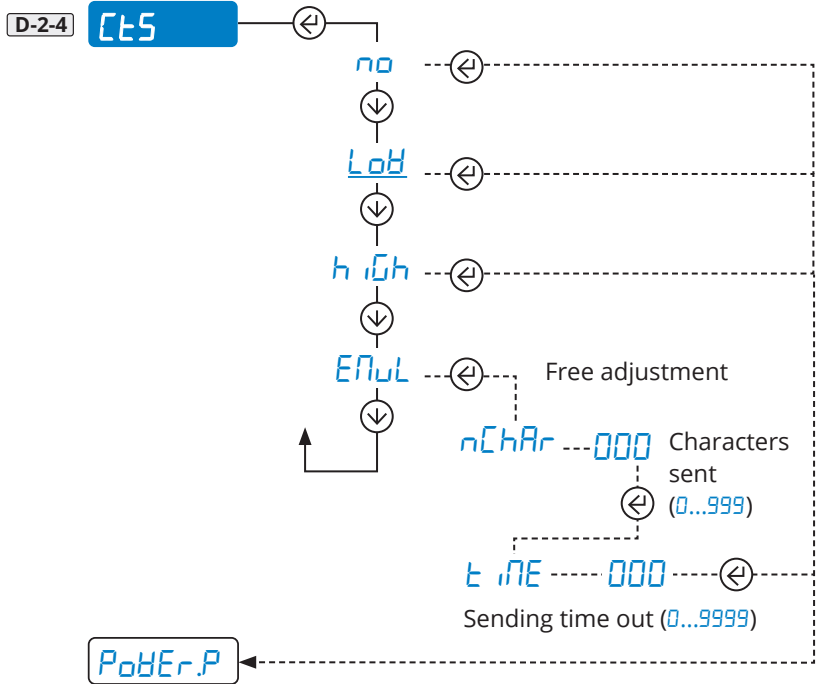

## Printer control signal

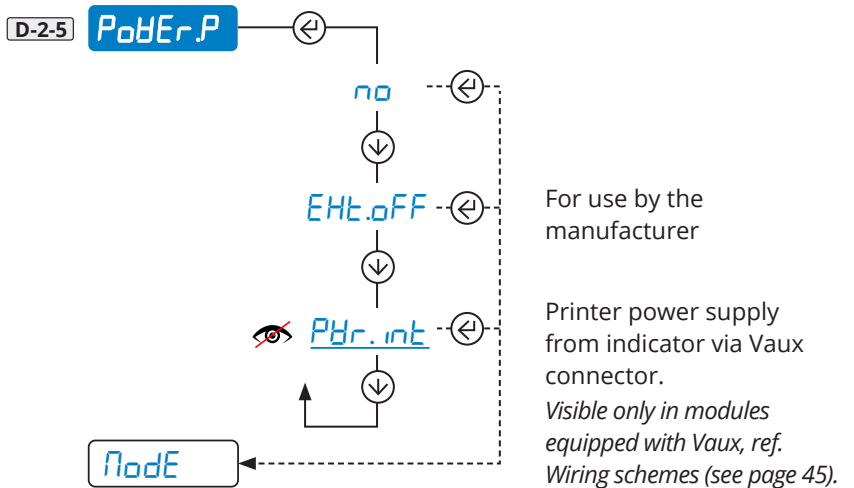

## Printer power supply / Radio-frequency module











How to enter

1. Off 
2. On 
3. 

 Page 8

How to browse

-  = 
-  = 
-  = 
-  = 

How to save and exit



 Page 8

- A CAL
- B D.CAL
- C GrAU
- D **SEr iAL**
- E LAYout
- F iLteEr
- G SCrEEen
- H bAtt
- I ECo.bAtt
- J AutoFF
- K rENotE
- L An.out
- M inPutS
- N outPut
- O rESEt
- P d iAG
- Q AdVAnC

- 1 CoN.PC
- 2 CoN.Prn

- 3 **AdVAnC**
- 1 **ProtoC**
- 2 **rAd io**
- 3 **tLtL t iL**
- 4 **tErn**
- 5 **iGnorE**

**AdVAnC** Advanced configurations 

Communication protocol

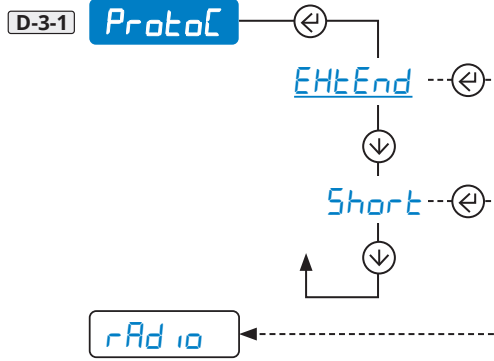

 For communication strings and controls, see page 42 - 43.

Connection port of radio-frequency module (for use by the manufacturer)

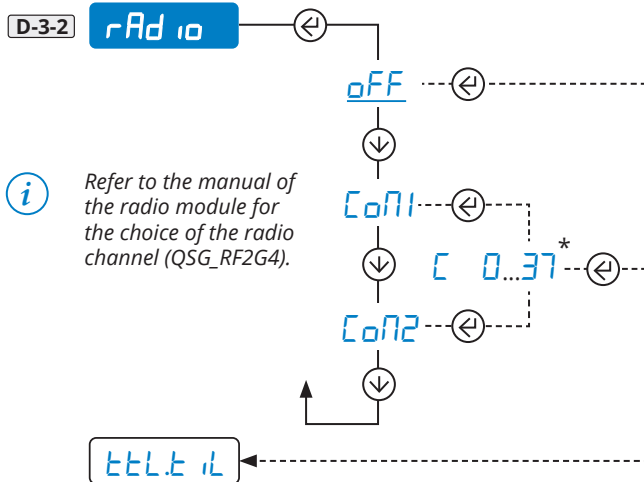

 Refer to the manual of the radio module for the choice of the radio channel (QSG\_RF2G4).

\* Selection of the radio channel.

TTL port / Inclinometer activation (for use by the manufacturer)

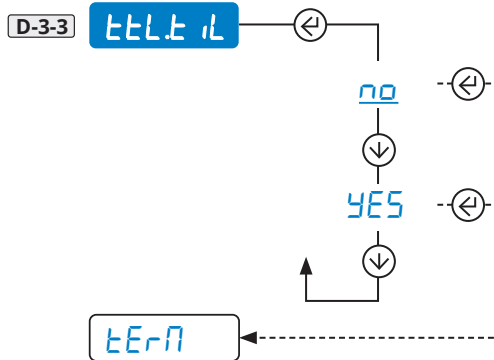

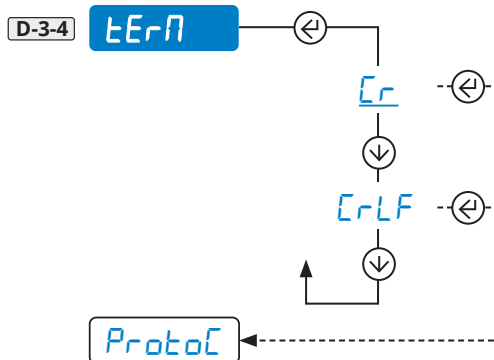

 Only for DFWL models.

Closing character of each print line













How to enter

1. Off 
2. On 
3. 

 Page 8

How to browse

-  = 
-  = 
-  = 
-  = 

How to save and exit



 Page 8

A CAL

B D.CAL

C GrAU

D SEr iAL

E LAYout

F iLteEr

G SCrEEen

H bAtt

I ECo.bAt

J AutoFF

K rENotE

L An.out

M inPutS

N outPut

O rESEt

P d iAG

Q AdUAnC

1 CoN.PC

2 CoN.Prn

3 AdUAnC

1 ProtoC

2 rAd io

3 tLt.t iL

4 tErn

5 iGnorE

AdUAnC Advanced configurations 

Ignore unknown commands

D-3-5

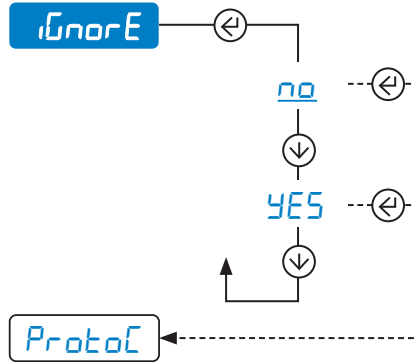

 When an unknown command is sent:  
 - If you select NO, you receive the answer "ERR04".  
 - If you select YES, the command is ignored (no message).



How to enter

- 1. Off
- 2. On
- 3.

Page 8

How to browse

- =
- =
- =
- =

How to save and exit



Page 8

- A
- B
- C
- D
- E 
  - 1
  - 2
  - 3
  - 4
  - 5
  - 6
  - 7
  - 8
  - 9
  - 10
  - 11
  - 12
  - 13
  - 14
  - 15
  - 16
  - 17
  - 18

Parameters for receipt/label mode

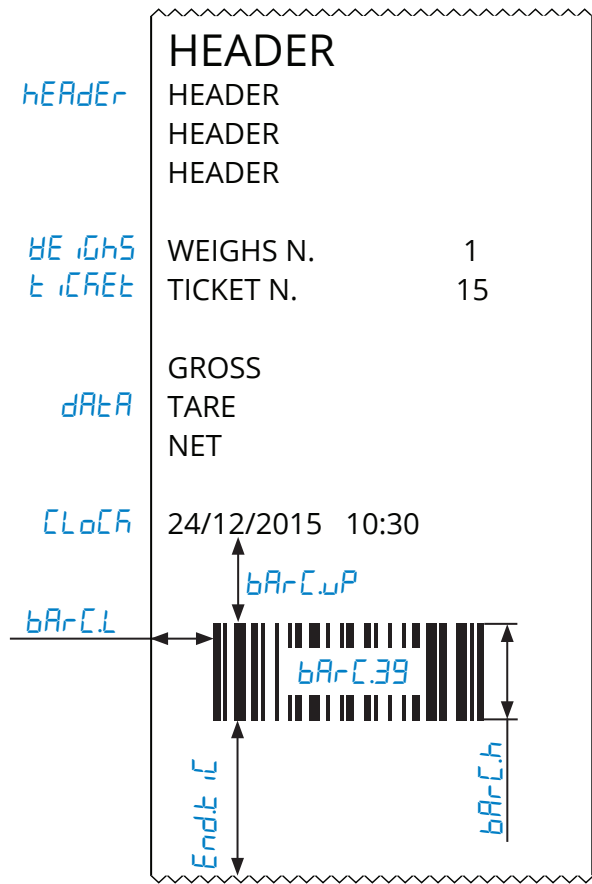

Additional parameters for label mode

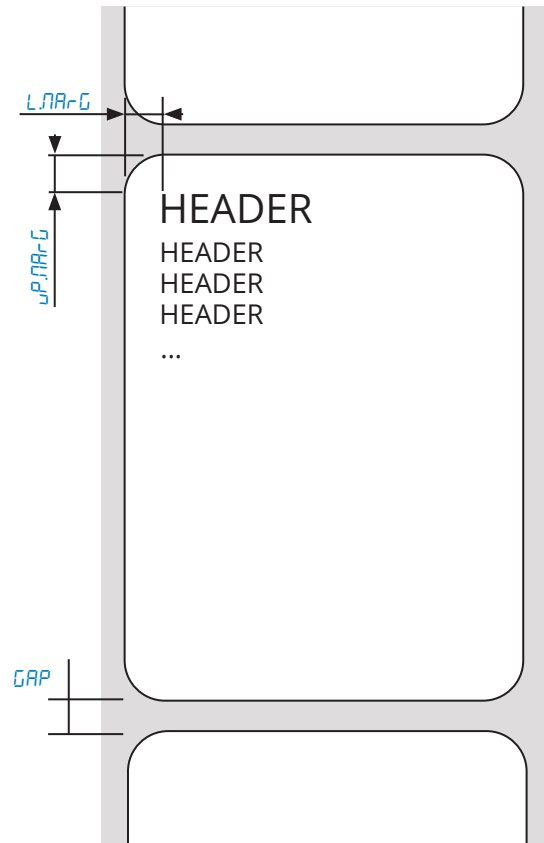

# MENU

How to enter

1. Off
2. On
- 3.

Page 8

How to browse

- =
- =
- =
- =

How to save and exit



Page 8

<b>A</b> CAL			
<b>B</b> O.CAL			
<b>C</b> GrAU			
<b>D</b> SEr iAL			
<b>E</b> LAYout			
<b>F</b> iLteR	<b>1</b> LANG		
<b>G</b> SCrEEen	<b>2</b> ChAr		
<b>H</b> bAtt	<b>3</b> hEAdEr	<b>1</b> ChAr 1	
<b>I</b> ECobAt	<b>4</b> dAtA	<b>2</b> ChAr 2	
<b>J</b> AutoFF	<b>5</b> HE iGhS		
<b>K</b> rENotE	<b>6</b> t iCREt		
<b>L</b> An.out	<b>7</b> CLoCh		
<b>M</b> inPutS	<b>8</b> bARCL39		
<b>N</b> outPut	<b>9</b> bARCLuP		
<b>O</b> rESEt	<b>10</b> bARCL		
<b>P</b> d iAG	<b>11</b> bARCh		
<b>Q</b> AdUAnC	<b>12</b> bARCLdt		
	<b>13</b> CoP iES		
	<b>14</b> Endt iC		
	<b>15</b> bL inE		
	<b>16</b> LAbEL		
	<b>17</b> Lb.SAUe		
	<b>18</b> tEst		

Setting of the print language

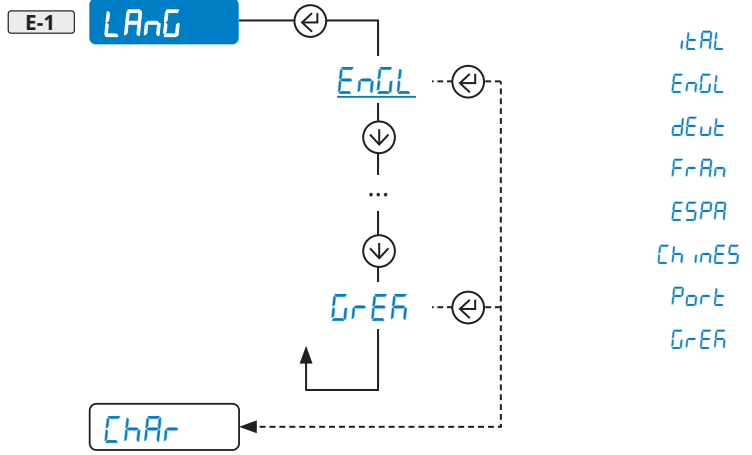

Character dimensions

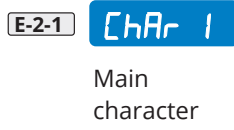

Label mode

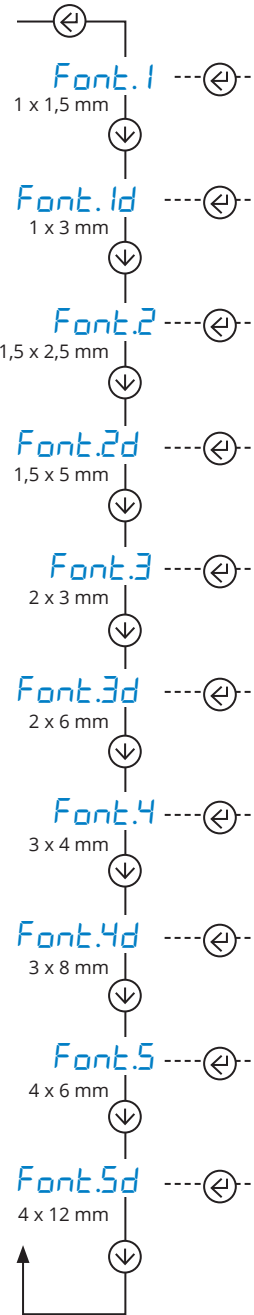

Receipt mode

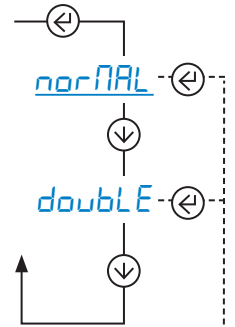

How to enter

- 1. Off
- 2. On
- 3.

Page 8

How to browse

- =
- =
- =
- =

How to save and exit



Page 8

A	CAL		
B	0.CAL		
C	GrAU		
D	SEr iAL		
E	<b>LAYout</b>		
F	F iLteR	1	LANg
G	SCrEEEn	2	ChAr
H	bAtt	3	<b>hEADer</b>
I	ECobAtt	4	dAtA
J	AutOFF	5	<b>1 EnABLE</b>
K	rENotE	6	<b>2 L inE 1</b>
L	An.out	7	<b>3 L inE 2</b>
M	inPutS	8	<b>4 L inE 3</b>
N	outPut	9	<b>5 L inE 4</b>
O	rESEt	10	bARCL
P	d iAG	11	bARCh
Q	AdVAnC	12	bARCLdt
		13	CoP iES
		14	Endt iC
		15	b.L inE
		16	LAbEL
		17	LbSAVE
		18	tEst

**hEADer** Print header



Enables header printing

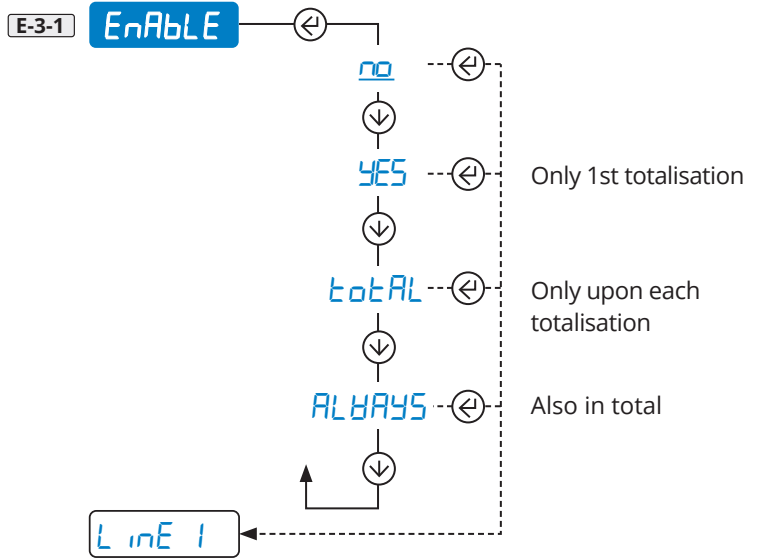

Contents of the header lines

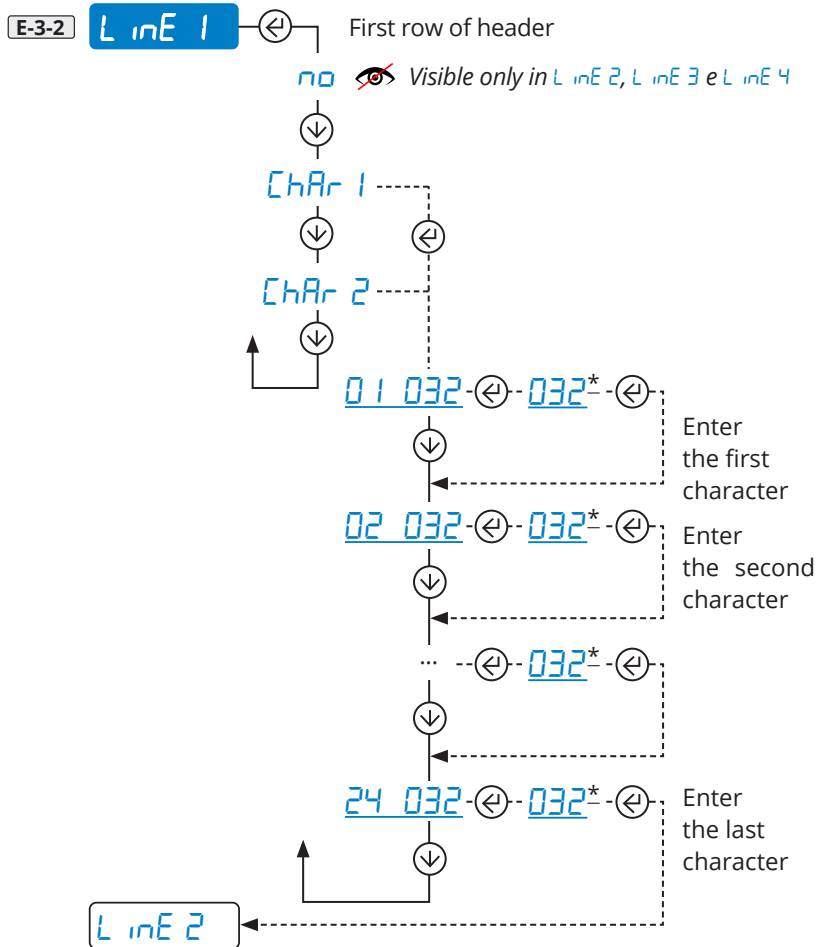

How to set the value

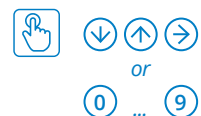

Repeat the operation to program L inE 2, L inE 3 and L inE 4. Select **no** to disable them.

# MENU

## How to enter

- Off
- On
- 

Page 8

## How to browse

- =
- =
- =
- =

## How to save and exit



Page 8

- A
- B
- C
- D
- E 
  - 1
  - 2
  - 3 
    - 1
    - 2
    - 3
    - 4
    - 5
  - 4
  - 5
  - 6
  - 7
  - 8
  - 9
  - 10
  - 11
  - 12
  - 13
  - 14
  - 15
  - 16
  - 17
  - 18
- F
- G
- H
- I
- J
- K
- L
- M
- N
- O
- P
- Q

## How to print/delete the row being programmed

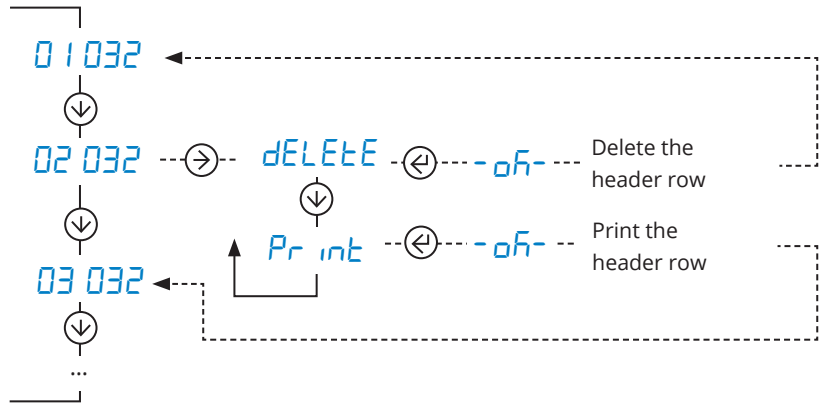

## Programming example

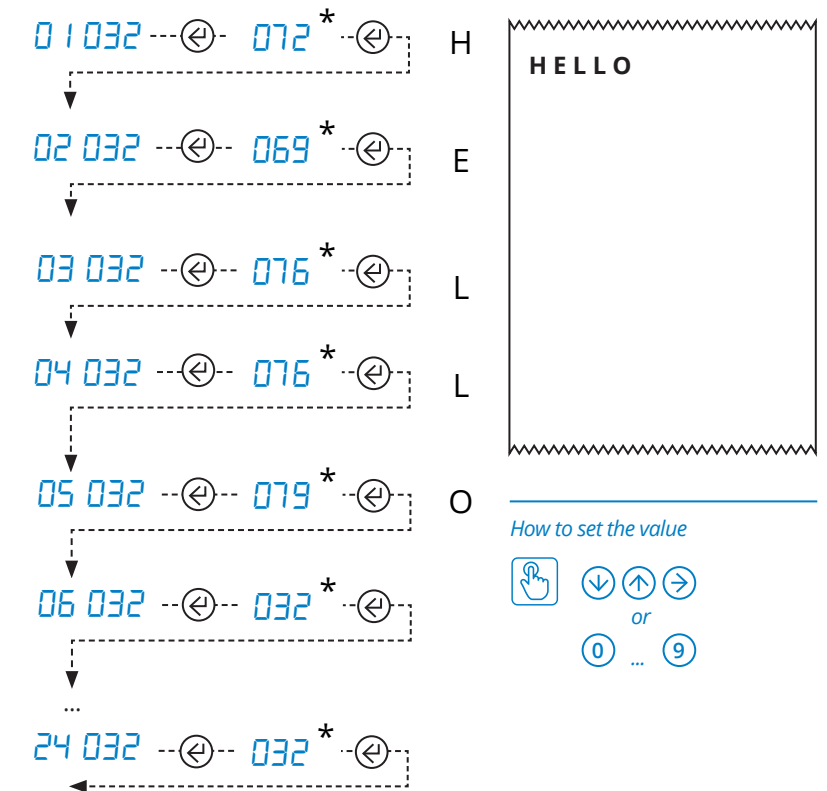

## List of characters

(\*)

32		47	/	62	>	77	M	92	\	107	k	122	z
33	!	48	0	63	?	78	N	93	]	108	l	123	{
34	"	49	1	64	@	79	O	94	^	109	m	124	
35	#	50	2	65	A	80	P	95	_	110	n	125	}
36	\$	51	3	66	B	81	Q	96	'	111	o	126	~
37	%	52	4	67	C	82	R	97	a	112	p		
38	&	53	5	68	D	83	S	98	b	113	q		
39	'	54	6	69	E	84	T	99	c	114	r		
40	(	55	7	70	F	85	U	100	d	115	s		
41	)	56	8	71	G	86	V	101	e	116	t		
42	*	57	9	72	H	87	W	102	f	117	u		
43	+	58	:	73	I	88	X	103	g	118	v		
44	,	59	;	74	J	89	Y	104	h	119	w		
45	-	60	<	75	K	90	Z	105	i	120	x		
46	.	61	=	76	L	91	[	106	j	121	y		



# MENU

How to enter

1. Off
2. On
- 3.

Page 8

How to browse

- =
- =
- =
- =

How to save and exit



Page 8

- A
- B
- C
- D
- E
- F
- G
- H
- I
- J
- K
- L
- M
- N
- O
- P
- Q
- 1
- 2
- 3
- 4
- 5
- 6
- 7
- 8
- 9
- 10
- 11
- 12
- 13
- 14
- 15
- 16
- 17
- 18

## Selection of the weight data

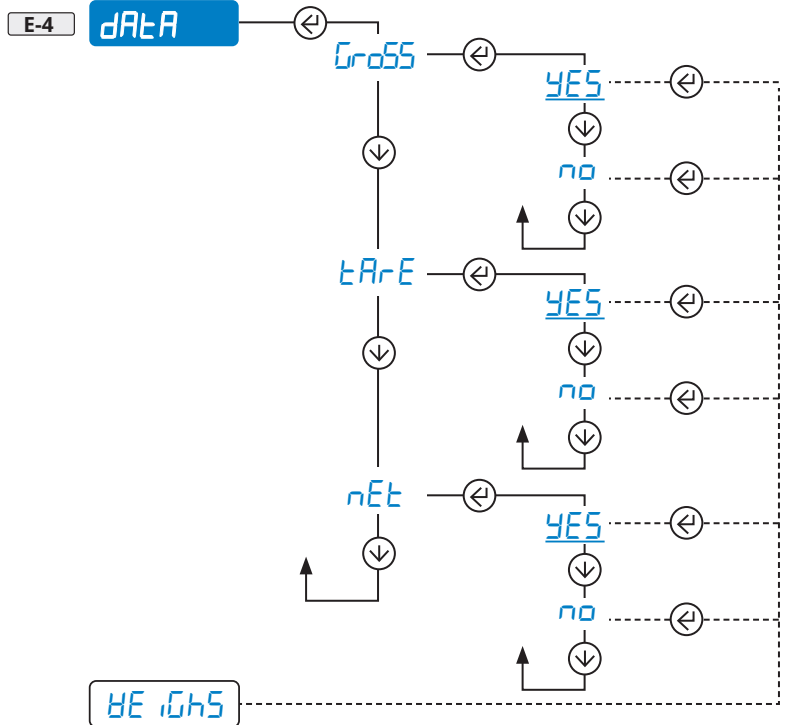

## Progressive weighed

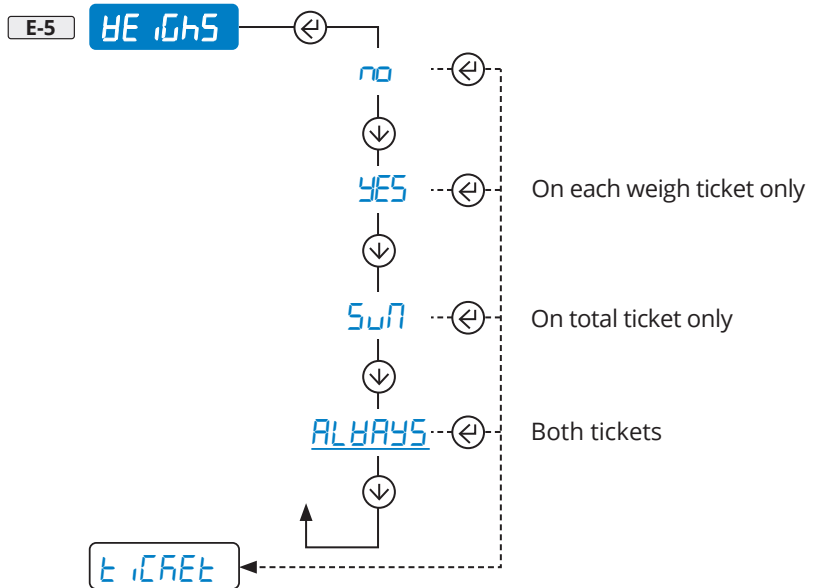

## Receipt/label progressive

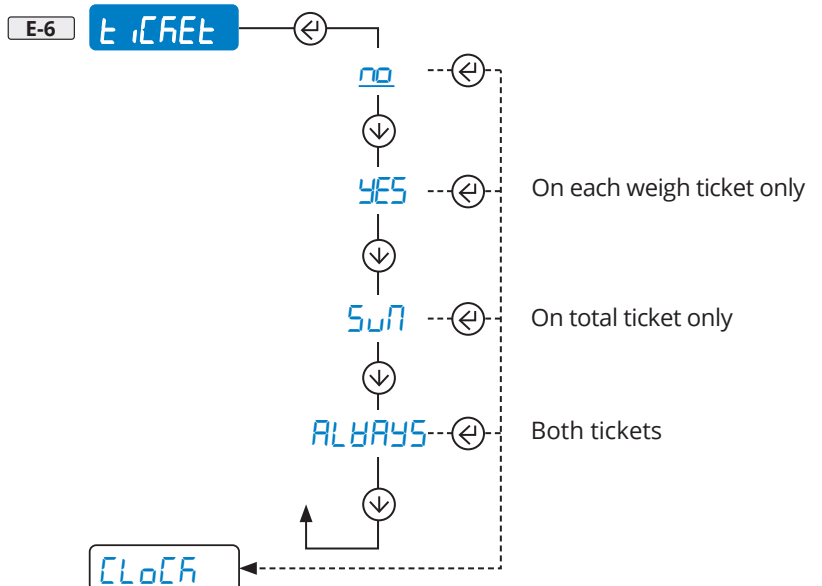

How to enter

1. Off
2. On
- 3.

Page 8

How to browse

- =
- =
- =
- =

How to save and exit



Page 8

- A
- B
- C
- D
- E 
  - 1
  - 2
  - 3
  - 4
  - 5
  - 6
  - 7
  - 8
  - 9
  - 10
  - 11
  - 12
  - 13
  - 14
  - 15
  - 16
  - 17
  - 18

## Date and time

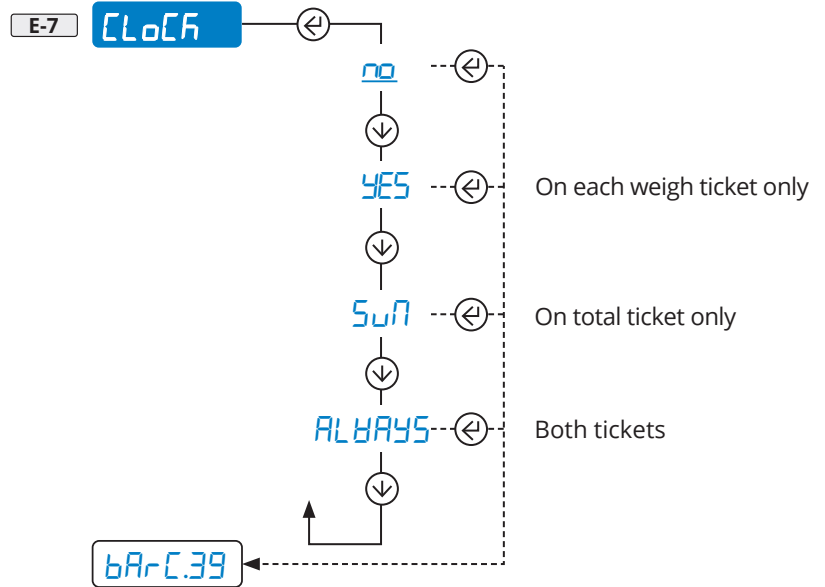

## Bar code 39

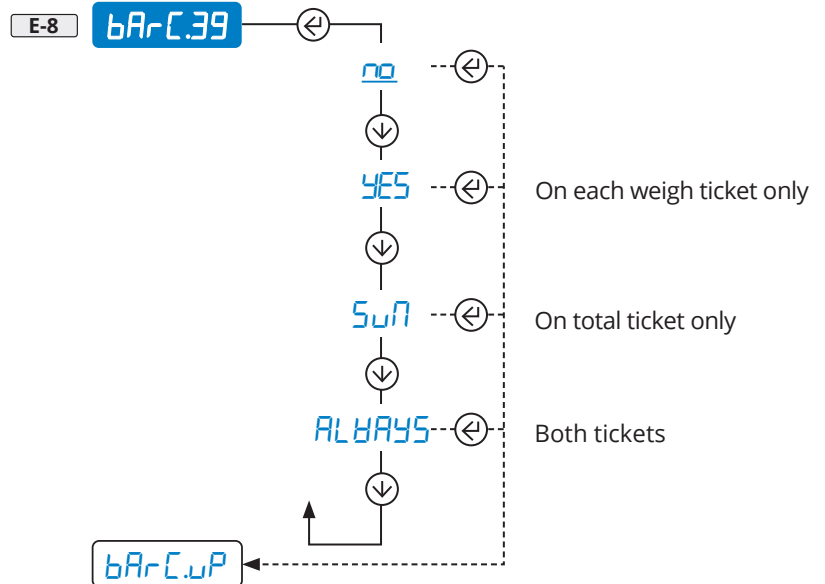

## Barcode top margin (mm)

Visible only if **bArC.39** (E-8) is active

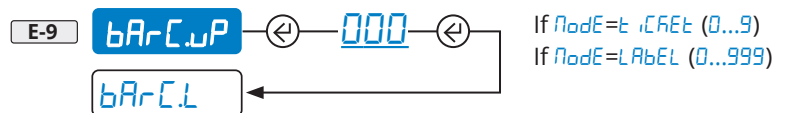

## Barcode left margin (mm)

Visible only if **bArC.39** (E-8) is active

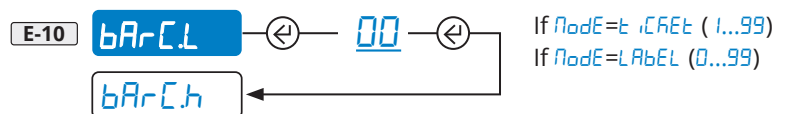

## Barcode height (mm)

Visible only if **bArC.39** (E-8) is active

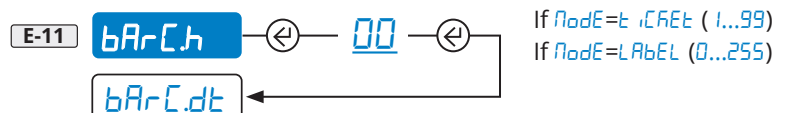

How to enter

1. Off
2. On
- 3.

Page 8

How to browse

- =
- =
- =
- =

How to save and exit



Page 8

- A
- B
- C
- D
- E 
  - 1
  - 2
  - 3
  - 4
  - 5
  - 6
  - 7
  - 8
  - 9
  - 10
  - 11
  - 12 
    - 13
    - 14
    - 15
    - 16
    - 17
    - 18

Selection of the weight data

Visible only if bARc.39 (E-8) is active

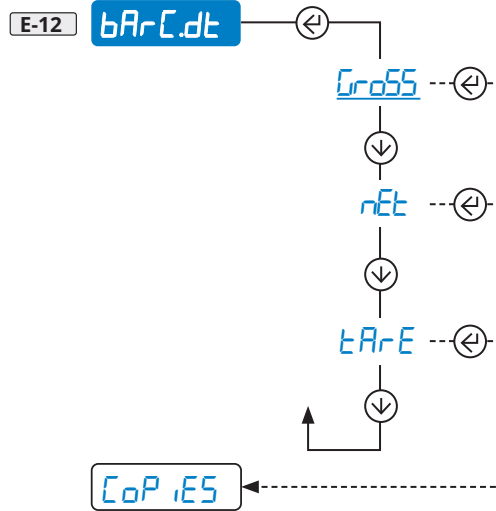

Multi-copy prints

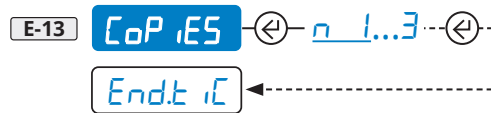

Paper outlet for end of label/receipt

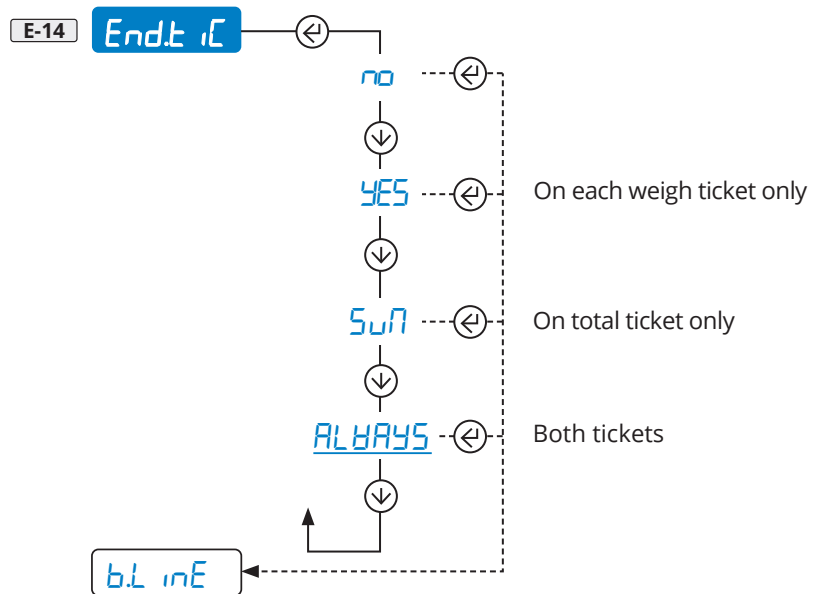

White pre-heating line of the print head  
(for thermal printer only)

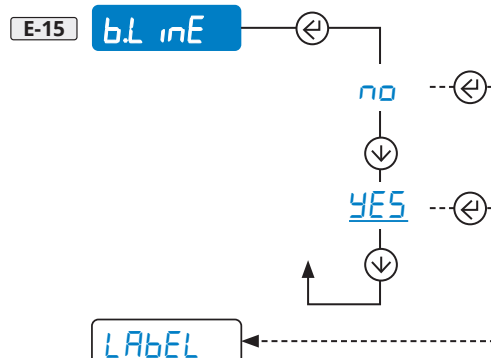



# MENU

How to enter

1. Off
2. On
- 3.

Page 8

How to browse

- =
- =
- =
- =

How to save and exit



Page 8

- A **CAL**
- B **OCAL**
- C **GRAU**
- D **SERIAL**
- E **LAYOUT**
  - 1 **LANG**
  - 2 **CHAR**
  - 3 **HEADER**
  - 4 **DATA**
  - 5 **HEIGHTS**
  - 6 **TEXT**
  - 7 **CLOCK**
  - 8 **BARCODE**
  - 9 **BARCODE P**
  - 10 **BARCODE L**
  - 11 **BARCODE h**
  - 12 **BARCODE dt**
  - 13 **COPYES**
  - 14 **ENDTEXT**
  - 15 **BLINK**
  - 16 **LABEL**
  - 17 **Lb.SAVE**
  - 18 **TEST**

## Label configuration

Visible only if  $\text{ModE (D-2-1)} = \text{LABEL}$

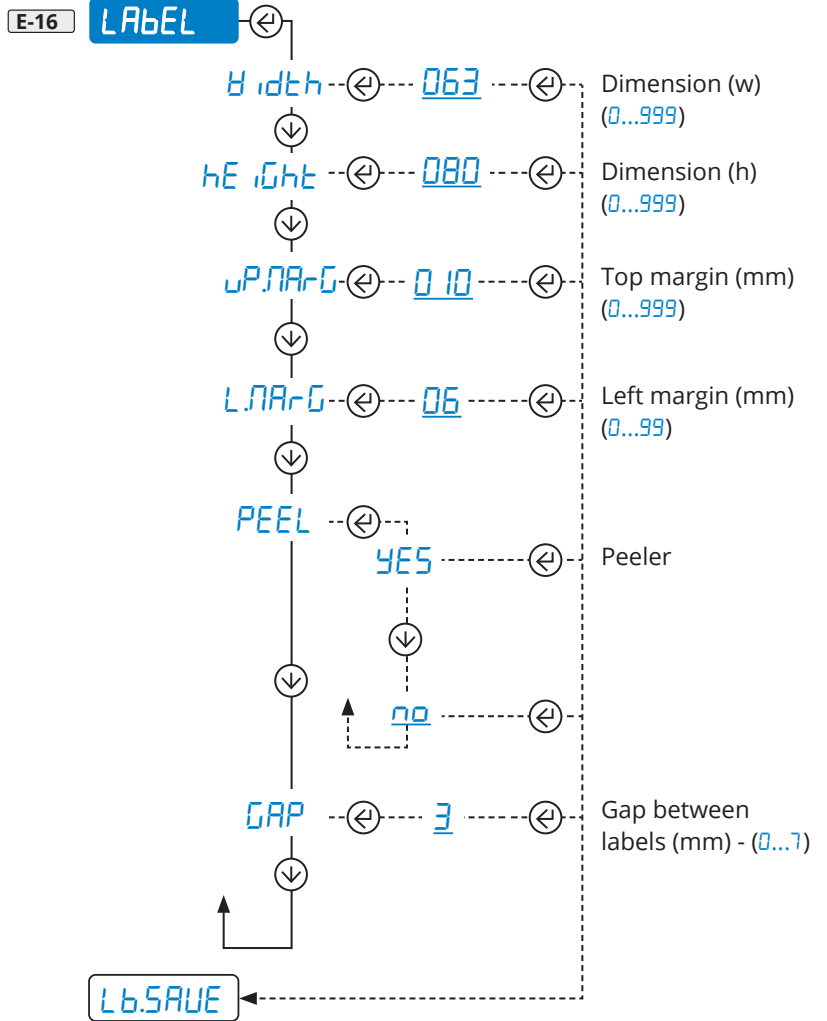

## Saving of labels in the printer memory

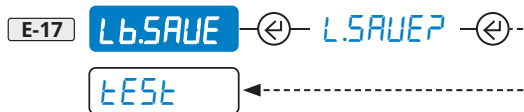

Visible only if  $\text{ModE (D-2-1)} = \text{LABEL}$

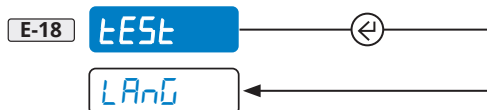

## Saving of labels in the printer memory (for label mode only) and test print of ALL FORMATS











How to enter

- 1. Off 
- 2. On 
- 3. 

 Page 8

How to browse

-  = 
-  = 
-  = 
-  = 

How to save and exit



 Page 8

- A CAL
- B O.CAL
- C GrAU
- D SEr iAL
- E LAYout
- F **F iLTER**
- G SCrEEen
  - 1 StAnd.0
  - ...
  - 4 StAnd.3
  - 5 h iRES.0
  - ...
  - 12 h iRES.7
  - 13 dYn.0
  - ...
  - 16 dYn.3
  - 17 SLoB.0
  - ...
  - 20 SLoB.3
  - 21 doS.0
  - ...
  - 24 doS.3
  - 25 rAdC 0
  - ...
  - 28 rAdC 5
- H bAtt
- I ECobAt
- J AutoFF
- K rENotE
- L An.out
- M inPutS
- N outPut
- O rESEt
- P d iAG
- Q AdVAnC



Edits scale reactivity.  
Useful to adjust the scale to your needs.

 With the approved instrument, you can select only some of the filters listed below (StAnd.0...3, h iRES.0 - 1, dYn.0 - 1, SLoB.0 - 1).

Premise:

The "0" represents minor filtering incidence.  
Increasing the incidence give the weight more stability.  
We recommend weighing several times, changing the incidence until you obtain the best compromise between reactivity and stability.

Table and floor scales and piece counters

F-1 StAnd.0

...

F-4 StAnd.3

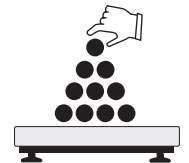

High precision scales

F-5 h iRES.0

...

F-12 h iRES.7



Suspended and oscillating load weighing

F-13 dYn.0

...

F-16 dYn.3



Liquid weighing, weighbridges and weighing with vibrations

F-17 SLoB.0

...

F-20 SLoB.3



Metering, filling, level check and overloads

F-21 doS.0

...

F-24 doS.3



Filter for specific applications for use by the manufacturer

F-25 rAdC 0

...

F-28 rAdC 5

### How to enter

1. Off
2. On
- 3.

Page 8

### How to browse

- ↑ =
- ↓ =
- =
- ← =

### How to save and exit



Page 8

- A
- B
- C
- D
- E
- F
- G 
  - H 
    - 1
    - 2
    - 3
    - 4
- I
- J
- K
- L
- M
- N
- O
- P
- Q



### Backlighting

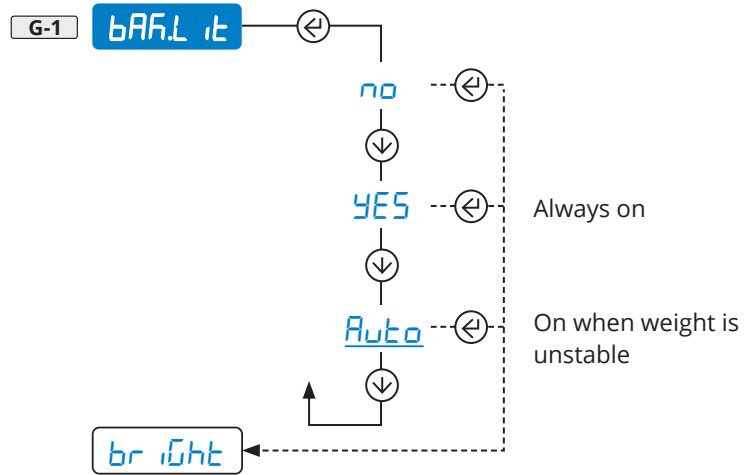

### Brightness

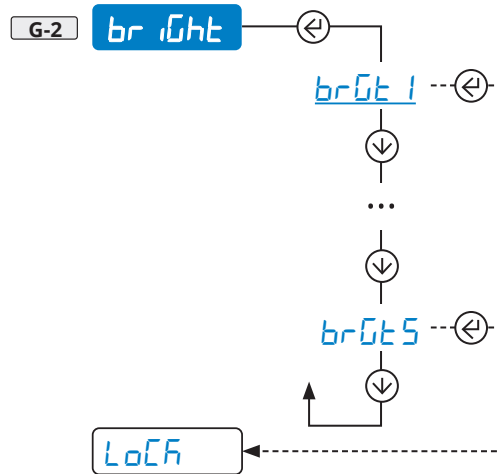

### Display lock (for use by the manufacturer)

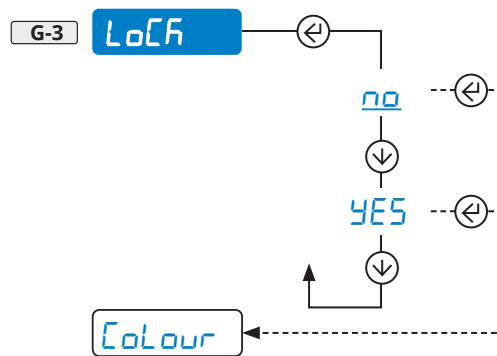

### Backlighting colour

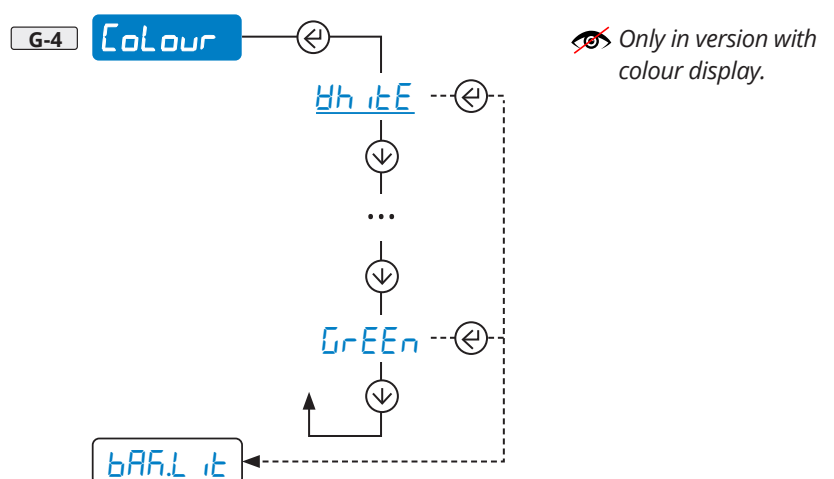

# MENU

How to enter

1. Off
2. On
- 3.

Page 8

How to browse

- =
- =
- =
- =

How to save and exit



Page 8

- A CAL
- B O.CAL
- C GrAU
- D SEr iAL
- E LAYout
- F iLteR
- G SCrEEen
- H **bAtE**
- I **ECobAtE**
- J AutoFF
- K rENotE
- L An.out
- M inPutS
- N outPut
- O rESEt
- P d iAG
- Q AdUAnC

## bAtE Power supply via battery

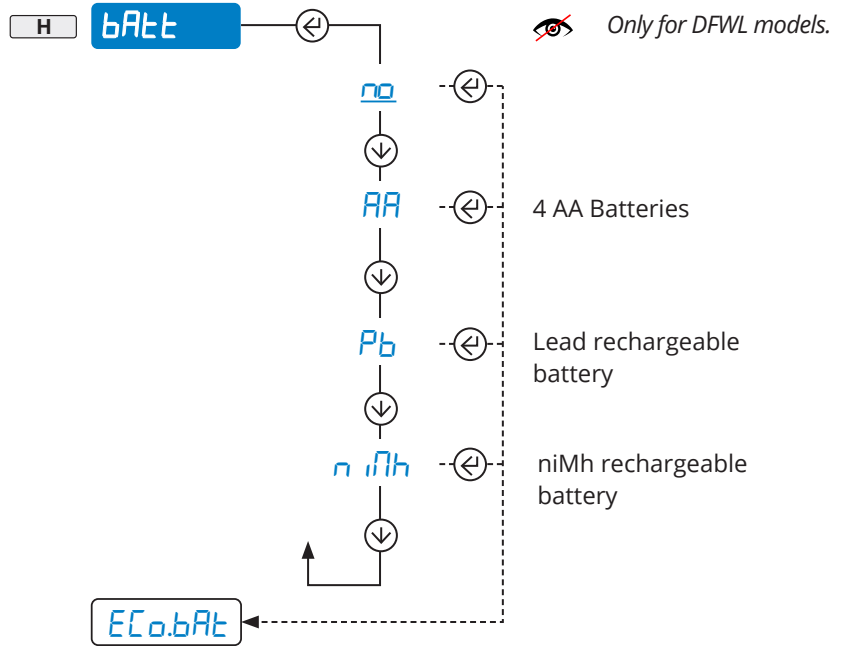

**WARNING:**  
only use original rechargeable batteries.

## ECobAtE Energy saving for battery operation

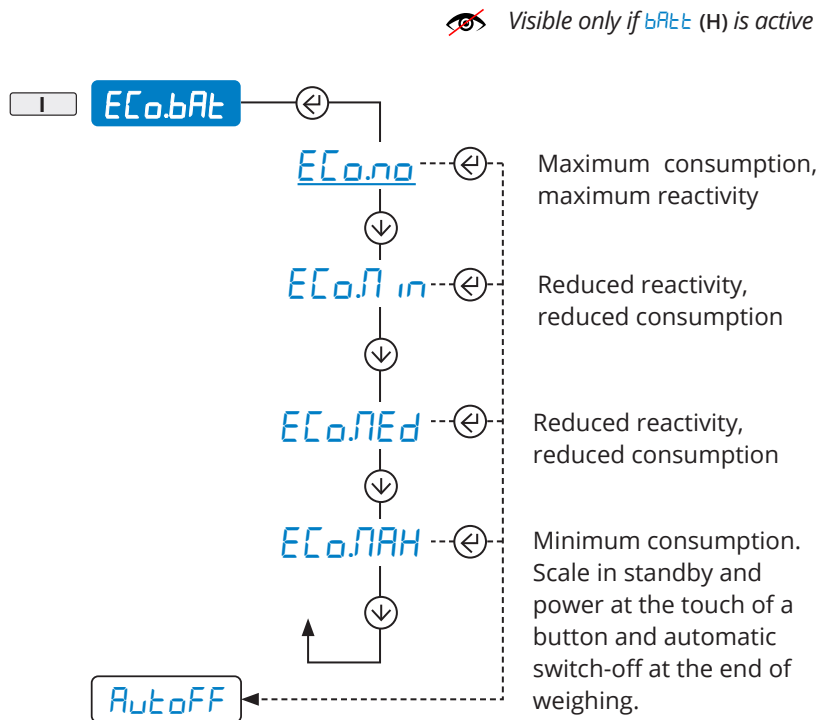

### How to enter

1. Off
2. On
- 3.

Page 8

### How to browse

- =
- =
- =
- =

### How to save and exit



Page 8

- A CAL
- B D.CAL
- C GrAU
- D SEr iAL
- E LAYout
- F iLteEr
- G SCrEEr
- H bAtte
- I ECo.bAt
- J **AutoFF**
- K **rENotE**
- L An.out
- M inPutS
- N outPut
- O rESEt
- P d iAG
- Q AdVAnC

## AutoFF Auto off

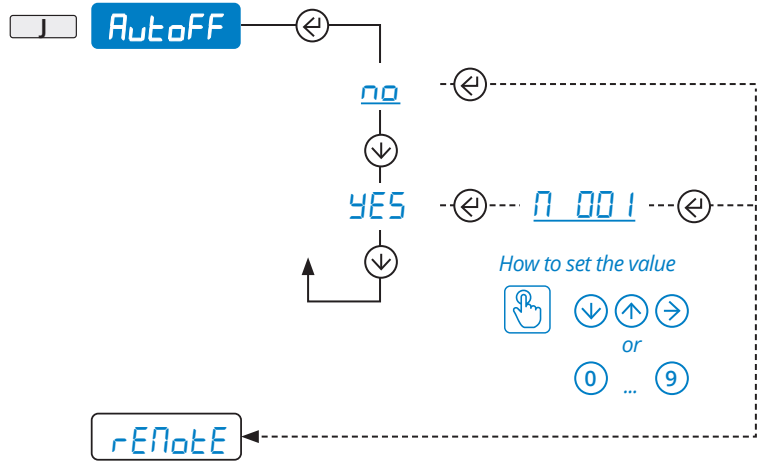

## rENotE Remote control

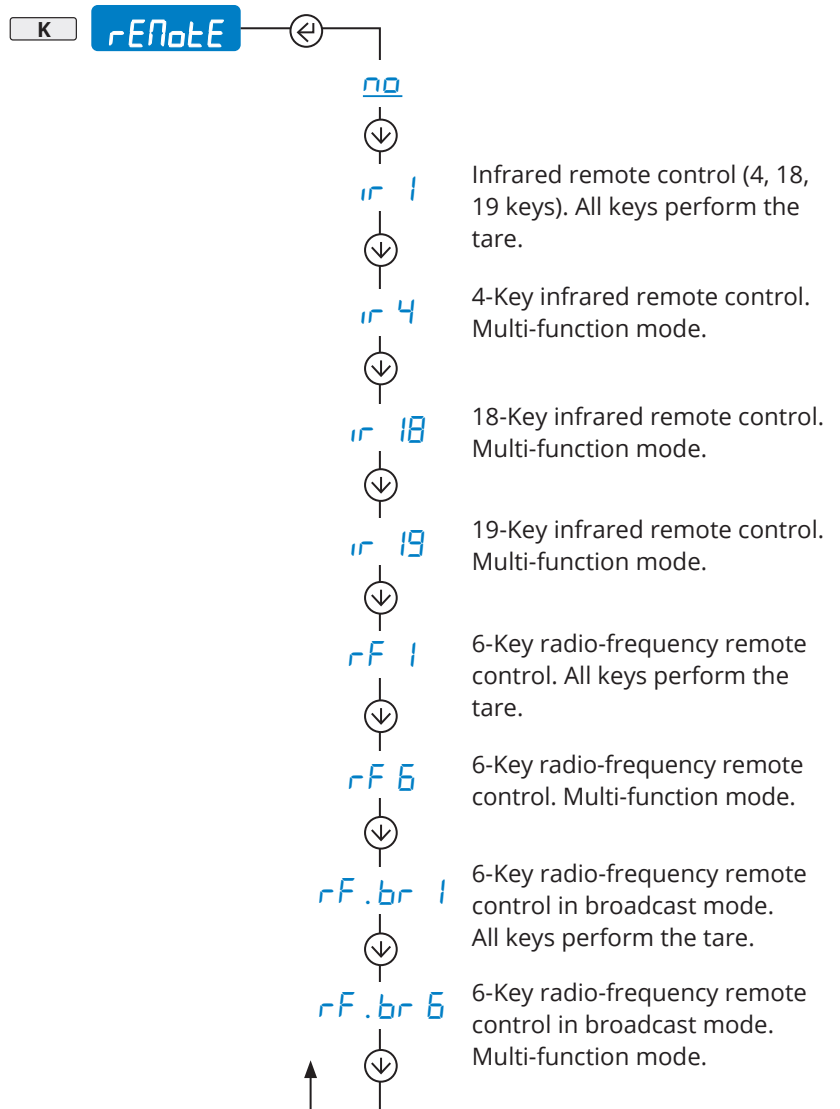

The broadcast mode allows sending the control to multiple scales simultaneously.



How to enter

1. Off
2. On
- 3.

Page 8

How to browse

- =
- =
- =
- =

How to save and exit



Page 8

- A CAL
- B DCAL
- C GrAU
- D SEr iAL
- E LAYout
- F iLteR
- G SCrEEen
- H bAtte
- I ECoBAte
- J AutoFF
- K rENotE
- L **An.out**
  - 1 nEt
  - 2 Pnt.und
  - 3 Hgt.1
  - 4 Pnt.1
  - 5 Hgt.2
  - 6 Pnt.2
  - 7 Hgt.3
  - 8 Pnt.3
  - 9 Pnt.oUr
- M inPutS
- N outPut
- O rESEt
- P d iAG
- Q AdVAnC

Visible only in the presence of optional analog board.

Operation proportional to the net/gross weight

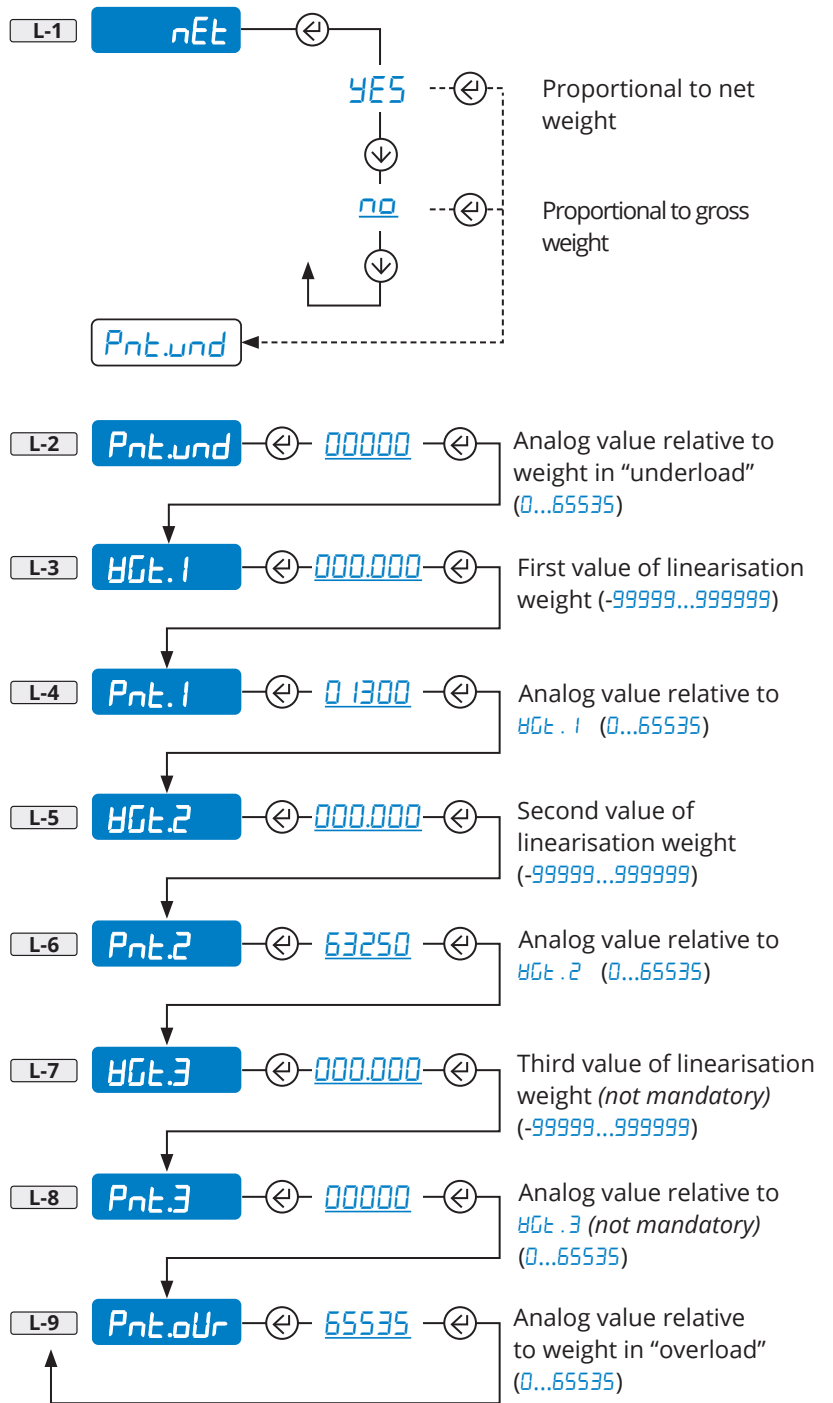

Thanks to the real-time upgrading of the output, using a tester you can check the value entered (see example page 31).

Value to be entered	Output volts	Output mA
1200	~ 0 V	~ 0 mA
11250		~ 4 mA
52200		~ 20 mA
62300	~ 10 V	

# MENU

How to enter

1. Off
  2. On
  - 3.
- Page 8

How to browse

- =
- =
- =
- =

How to save and exit



- A **CAL**
- B **0.CAL**
- C **GrAU**
- D **SEr iAL**
- E **LAYout**
- F **FiLteR**
- G **SCrEEen**
- H **bAtt**
- I **ECobAtt**
- J **AutoFF**
- K **rENotE**
- L **An.out**
  - 1 **nEt**
  - 2 **Pnt.und**
  - 3 **HGt.1**
  - 4 **Pnt.1**
  - 5 **HGt.2**
  - 6 **Pnt.2**
  - 7 **HGt.3**
  - 8 **Pnt.3**
  - 9 **Pnt.oUr**
- M **inPutS**
- N **outPut**
- O **rESEt**
- P **d iAG**
- Q **AdVAnC**

Programming example:

we want to program a linearisation point so that at 1000kg, the analog output supplies 10V.

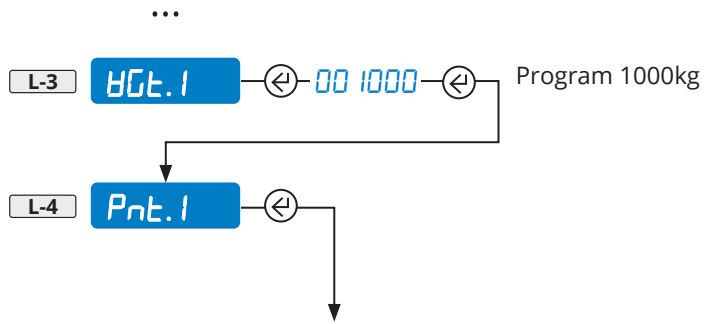

Enter **62300** (the reference value in the table) and check the analog output using a tester.

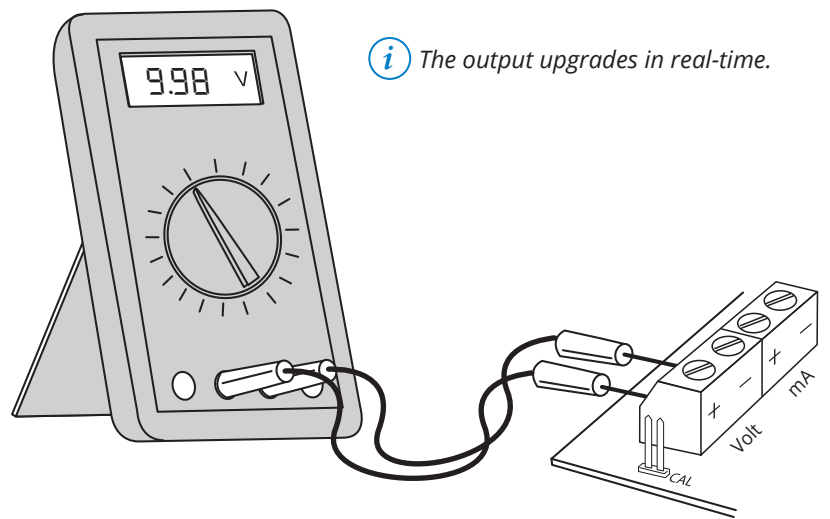

Adjust the analog output by increasing or decreasing the value. We recommend minimal changes of at least 10 points, (**62310**, **62320**, **62330**, etc.)

How to set the value

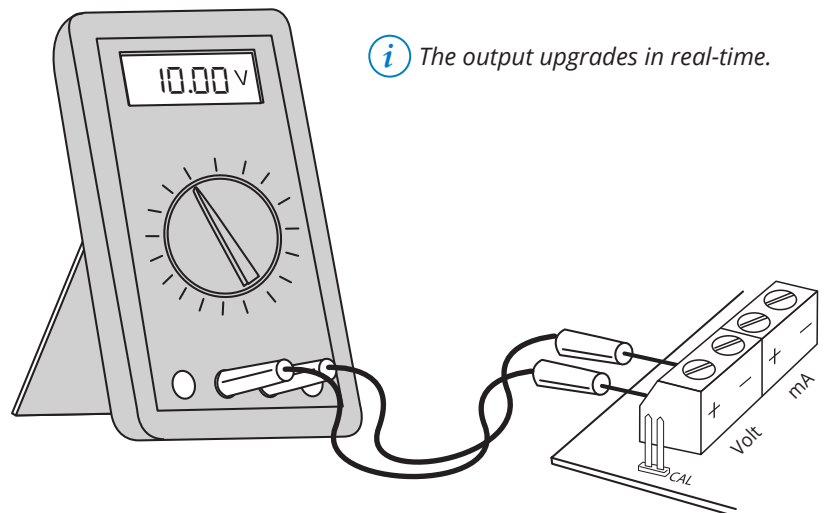

Once the desired adjustment has been made, confirm the value with .

# MENU

How to enter

1. Off
2. On
- 3.

Page 8

How to browse

- =
- =
- =
- =

How to save and exit



Page 8

- A CAL
  - B D.CAL
  - C GrAU
  - D SEr iAL
  - E LAYout
  - F iLteR
  - G SCrEEen
  - H bAtte
  - I ECobAt
  - J AutoFF
  - K rENotE
  - L An.out
  - M **inPutS**
  - N outPut
  - O rESEt
  - P d iAG
  - Q AdVAnC
- 1 **inP.b.1**
  - 2 **inP.b.2**
  - 3 **inP.b.3**
  - 4 **inP.b.4**

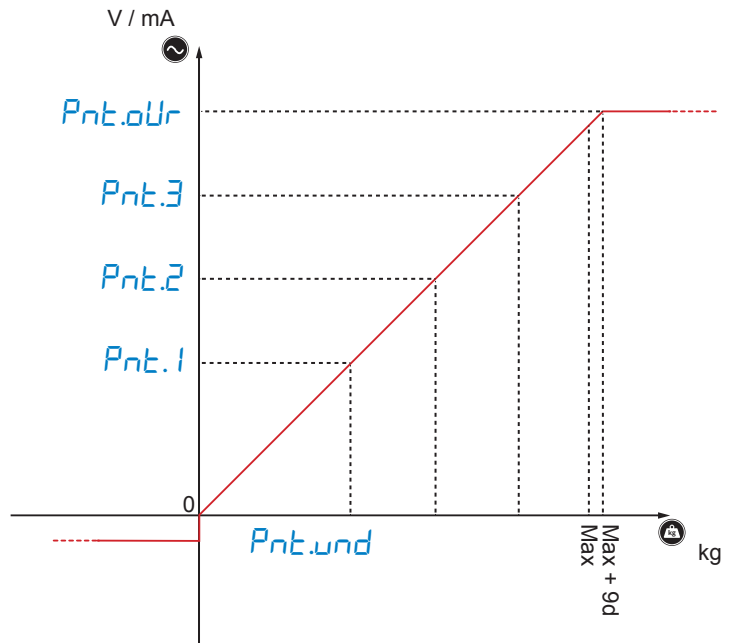

## inPutS Digital inputs



Input 1 configuration

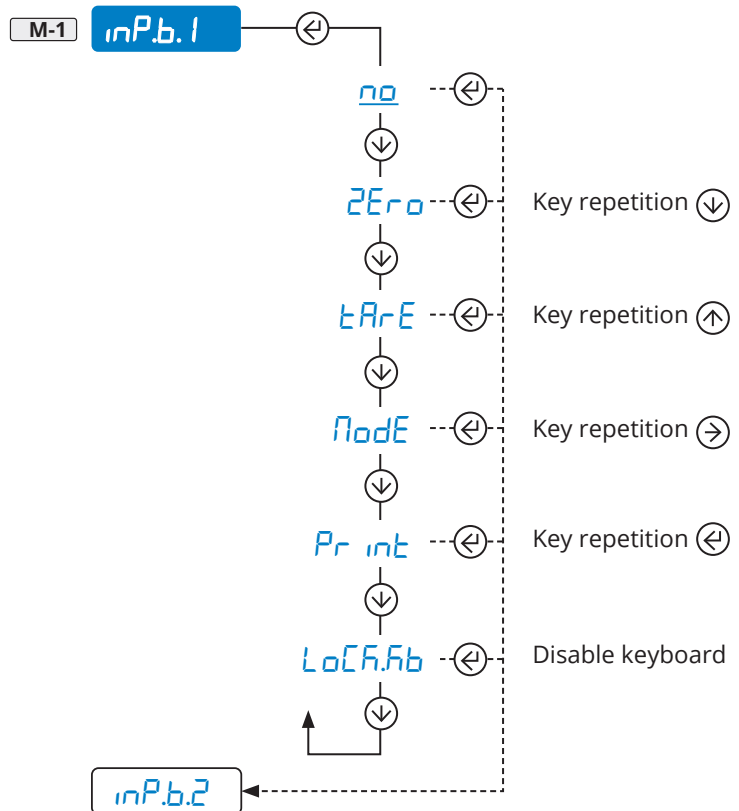

Repeat the same operation for inP.b.2, inP.b.3 e inP.b.4.



How to enter

1. Off
  2. On
  - 3.
- Page 8

How to browse

- ↑ =
- ↓ =
- =
- ← =

How to save and exit



A CAL

B O.CAL

C GrAU

D SEr iAL

E LAYout

F iLteEr

G SCrEEen

H bAtte

I ECo.bAt

J AutoFF

K rENotE

L An.out

M inPutS

N **outPut**

O rESEt

P d iAG

Q AdVAnC

1 rEL.b.1

2 rEL.b.2

3 rEL.b.3

4 rEL.b.4

5 rEL.b.5

6 rEL.b.6

1 Funct

2 Node

3 d irEct

4 h iStEr

outPut Digital outputs



Operation on net weight, gross weight or dosage

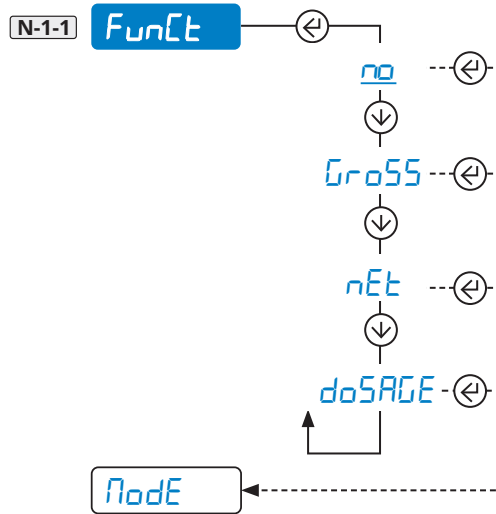

**For dosage / filling:**

- Start the *doSAGE* mode
- Set the *unLoAd* unladen weight.

The output is activated only after having set the unladen weight of the container (by key or via external button) and is turned off once the set target (setpoint) has been achieved. To perform fills at two speeds, you must programme two outputs in *doSAGE* mode.

Normally open (n.o.) or closed (n.c.) operation

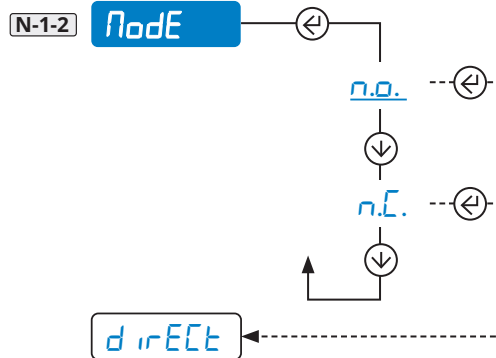

Output activation mode

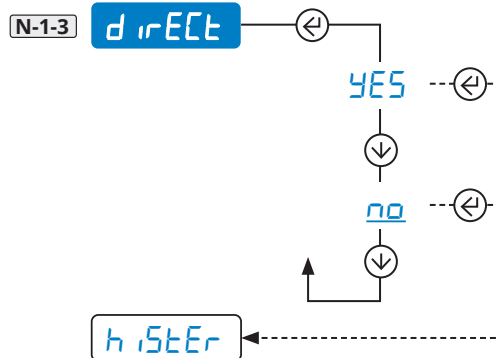

Direct, when weight is table or unstable

Only when weight is stable

Double threshold operation

(activation weight threshold ≠ from output deactivation weight threshold)

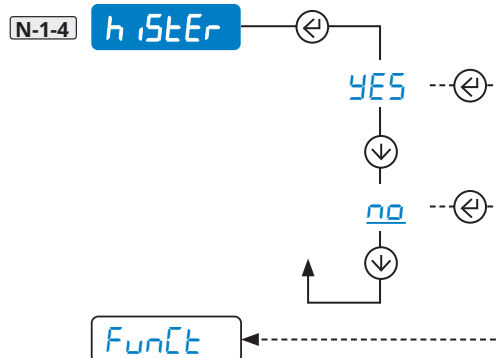

**Operation:**

YES (Double threshold)

no (Single threshold)

Repeat the same operation for *rEL . b . 2*, *rEL . b . 3*, *rEL . b . 4*, *rEL . b . 5* and *rEL . b . 6*.

# MENU

## How to enter

1. Off
2. On
- 3.

Page 8

## How to browse

- =
- =
- =
- =

## How to save and exit



Page 8

A CAL

B D.CAL

C GrAU

D SEr iAL

E LAYout

F iLteR

G SCrEEen

H bAtte

I ECoBAte

J AutoFF

K rENotE

L An.out

M inPutS

N outPut

O rESEt

P d iAG

Q AdUAnC

1 AdC.uU

2 d iSPLA

3 KEyb

4 CtS

5 outPut

6 inPutS

7 An.out

8 SEr.nuN

9 PrG.UEr

10 d iU. int

11 AdC.Pnt

12 bt.AdC

13 PH.AdC

14 SEr iAL

## rESEt Factory configuration reset

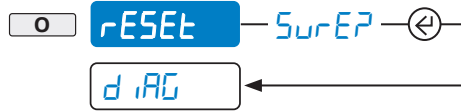

Function resetting the factory configurations while maintaining the calibration in the memory unchanged.

## d iAG Diagnostics



P-1 AdC.uU

Converter. Check of input signal in  $\mu\text{V}$ . In case of more equalised channels, press or to examine all the selected channels.

P-2 d iSPLA

Display. Integrity check of all segments and icons.

P-3 KEyb

Keyboard. Press any key to verify its correct operation, with beep and code on display.

P-4 CtS

CTS. Check of status of the control signal from the printer.

P-5 outPut

Optional digital outputs. Check the activation and deactivation of each contact.

**Example:** *out 1* activates output 1. Press to select the next output.

**WARNING:** before entering the *outPut* pitch, verify that the activation of the output does not cause dangerous conditions for people, animals or property.

P-6 inPutS

Optional digital inputs. Check the activation and deactivation of each input.

**Example:** *in 1-0* input not active

**Example:** *in 1-1* input active

Press to select the next input.

P-7 An.out

Analog output. Enter the digital value and using a tester check the response of the analog output.

P-8 SEr.nuN

Serial number of the scale.

P-9 PrG.UEr

Hardware revision (e.g. *rEU 5*) followed by software version (e.g. *04.00.00*).

P-10 d iU. int

For use by the manufacturer.

P-11 AdC.Pnt

For use by the manufacturer.

P-12 bt.AdC

For use by the manufacturer.

P-13 PH.AdC

For use by the manufacturer.

P-14 SEr iAL

For use by the manufacturer.



How to enter

1. Off
2. On
- 3.

Page 8

How to browse

- =
- =
- =
- =

How to save and exit



Page 8

A CAL

B 0.CAL

C GrAU

D SEr iAL

E LAYout

F iLteR

G SCrEEen

H bAtte

I ECobAt

J AutoFF

K rENotE

L An.out

M inPutS

N outPut

O rESEt

P d iAG

Q AdUAnC

1 CAL.PAr

2 EQuALP

3 CAL.AdU

4 nEtrol

5 KEyb

6 t iLte

7 rERAct

8 LoCkAb

9 AL ib i.r

10 P in.tEC

11 P in.uSE

12 dFLt.t

1 dEC .n

2 d iU

3 u.n.

4 rAnGE 1

5 rAnGE 2

6 rAnGE 3

7 EQuAL

8 n.ChAn



CAL.PAr Calibration parameters

Configuration of the decimal point (0...3)

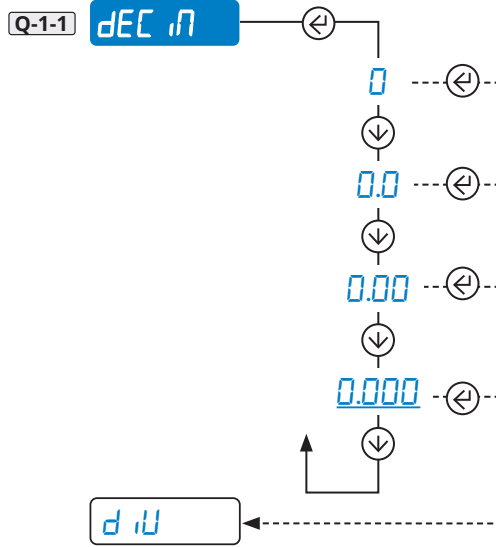

Reading division

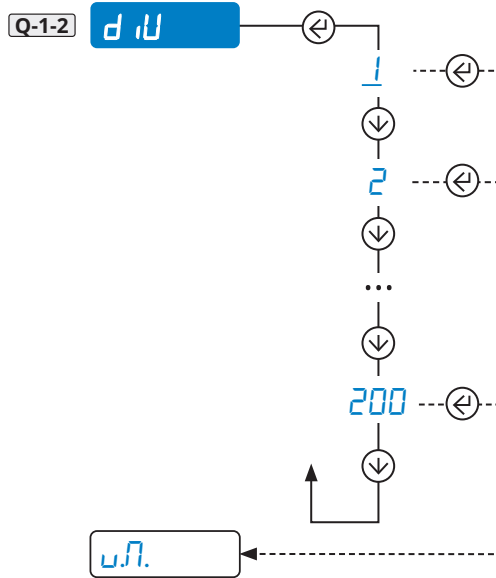

Unit of measure

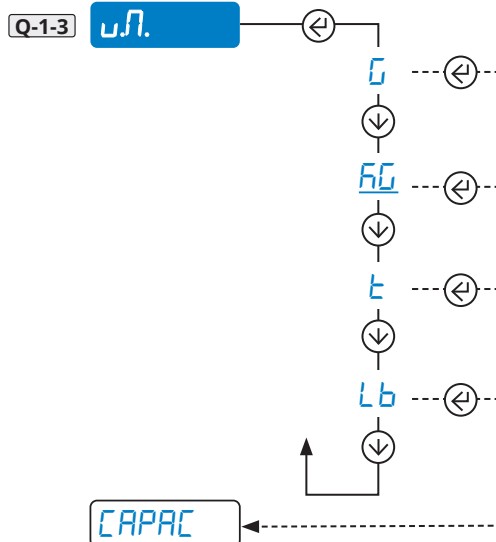

# MENU

## How to enter

- Off
- On
- 

Page 8

## How to browse

- =
- =
- =
- =

## How to save and exit



Page 8

A CAL

B O.CAL

C GrAU

D SEr iAL

E LAYout

F iLteR

G SCrEEen

H bAtte

I ECobAt

J AutoFF

K rENotE

L An.out

M inPutS

N outPut

O rESEt

P d iAG

Q AdUAnC

1 CAL.PAr

2 EQUALP

3 CAL.ADU

4 NEtroL

5 KEYb

6 t iLte

7 rERAct

8 LoCk.Rb

9 AL ib i.r

10 P in.tEC

11 P in.uSE

12 dFLt.t

1 dEC iN

2 d iU

3 u.N.

4 rAnGE 1

5 rAnGE 2

6 rAnGE 3

7 EQUAL

8 n.ChAn

Scale capacity. Set Max or Range 1 (Max range = 800.000)

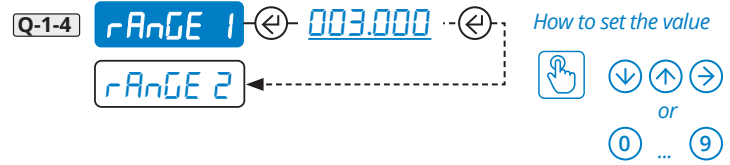

## Range 2

For multirange scales, set the second weighing range.

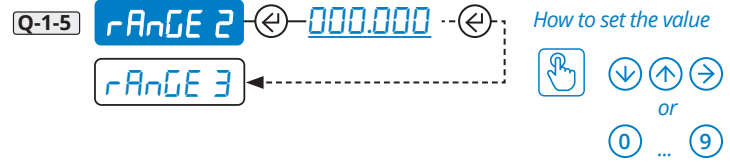

## Range 3

For multirange scales, set the third weighing range.

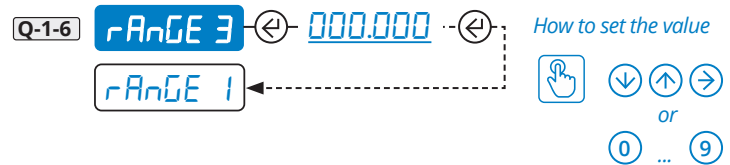

Example of multirange configuration at 1500/3000 kg, division 0.5/1 kg.

Set:

- dEC i = 0.0
- d iU = 5
- rAnGE 1 = 1500.0
- rAnGE 2 = 3000.0

## Equalisation function

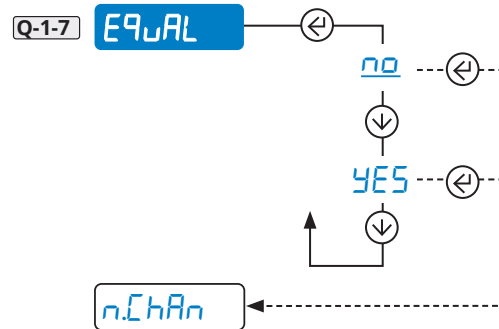



Connection diagram on page 7.  
Equalisation procedure on page 37.

## Equalised analog channels

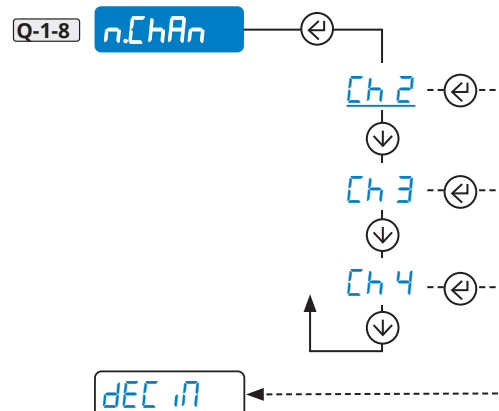
Visible only if EQUAL(Q-1-7)= YES











How to enter

1. Off 
2. On 
3. 

 Page 8

How to browse

-  = 
-  = 
-  = 
-  = 

How to save and exit



 Page 8

A CAL

B D.CAL

C GrAU

D SEr iAL

E LAYout

F iLteR

G SCrEEen

H bAtte

I ECoBAte

J AutoFF

K rENotE

L An.out

M inPutS

N outPut

O rESEt

P d iAG

Q AdUAnC

1 CALPAR

2 **EQUALP**

3 CALAdU

4 NEtroL

5 REYb

6 t iLte

7 rEAct

8 LoCRAb

9 AL ib iR

10 P in.tEC

11 P in.wSE

12 dFLte

1 E9.0

2 E9.1

3 E9.2

4 E9.3

5 E9.4



 **EQUALP** is only visible if the function **EQUAL** (Q-1-7) is activated in the menu **CALPAR** (Q-1).

The equalisation wizard asks to acquire the zero point with scale unloaded and to later place a weight of about 1/8 of the maximum capacity (Max) on each individual cell, in the required order. After the procedure the message **E9.off** will appear.

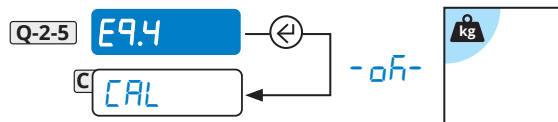
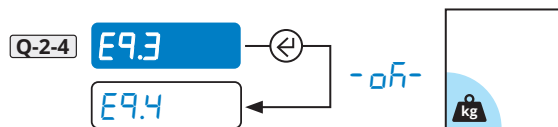
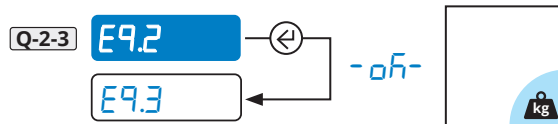
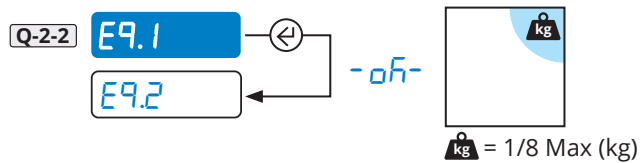
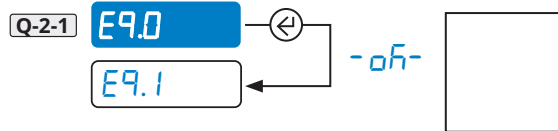
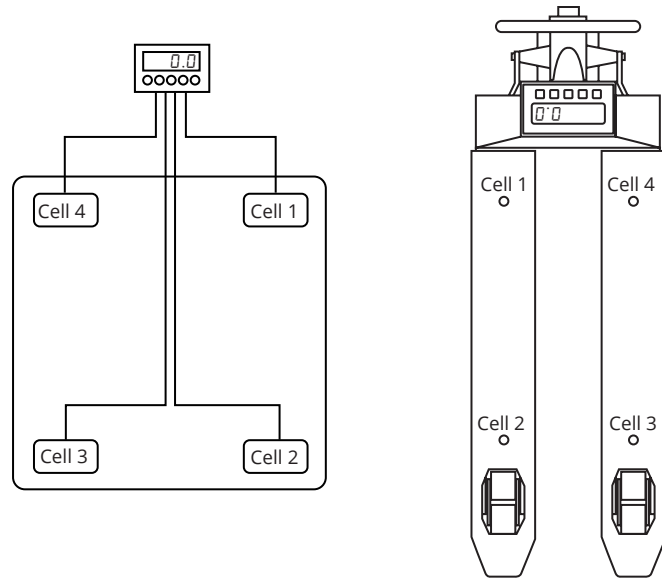
Proceed with the calibration.









How to enter

- 1. Off 
- 2. On 
- 3. 

 Page 8

How to browse

-  = 
-  = 
-  = 
-  = 

How to save and exit



 Page 8

A CAL

B O.CAL

C GrAU

D SEr iAL

E LAYout

F iLteR

G SCrEEen

H bAtte

I ECobAt

J AutoFF

K rENotE

L An.out

M inPutS

N outPut

O rESEt

P d iAG

Q AdUAnC

1 CAL.PAr

2 EQuALP

3 CAL.AdU

4 NEtroL

5 KEyb

6 t iLte

7 rERAct

8 LoCkAb

9 AL ib iR

10 P in.tEC

11 P in.uSE

12 dFLt.t

1 2Ero



CAL.AdU Complete calibration 

 Before calibrating, configure the decimals (dEE i - Q-1-1), the division (d iU - Q-1-2) and the capacity (rAnGE - Q-1-4,5,6).

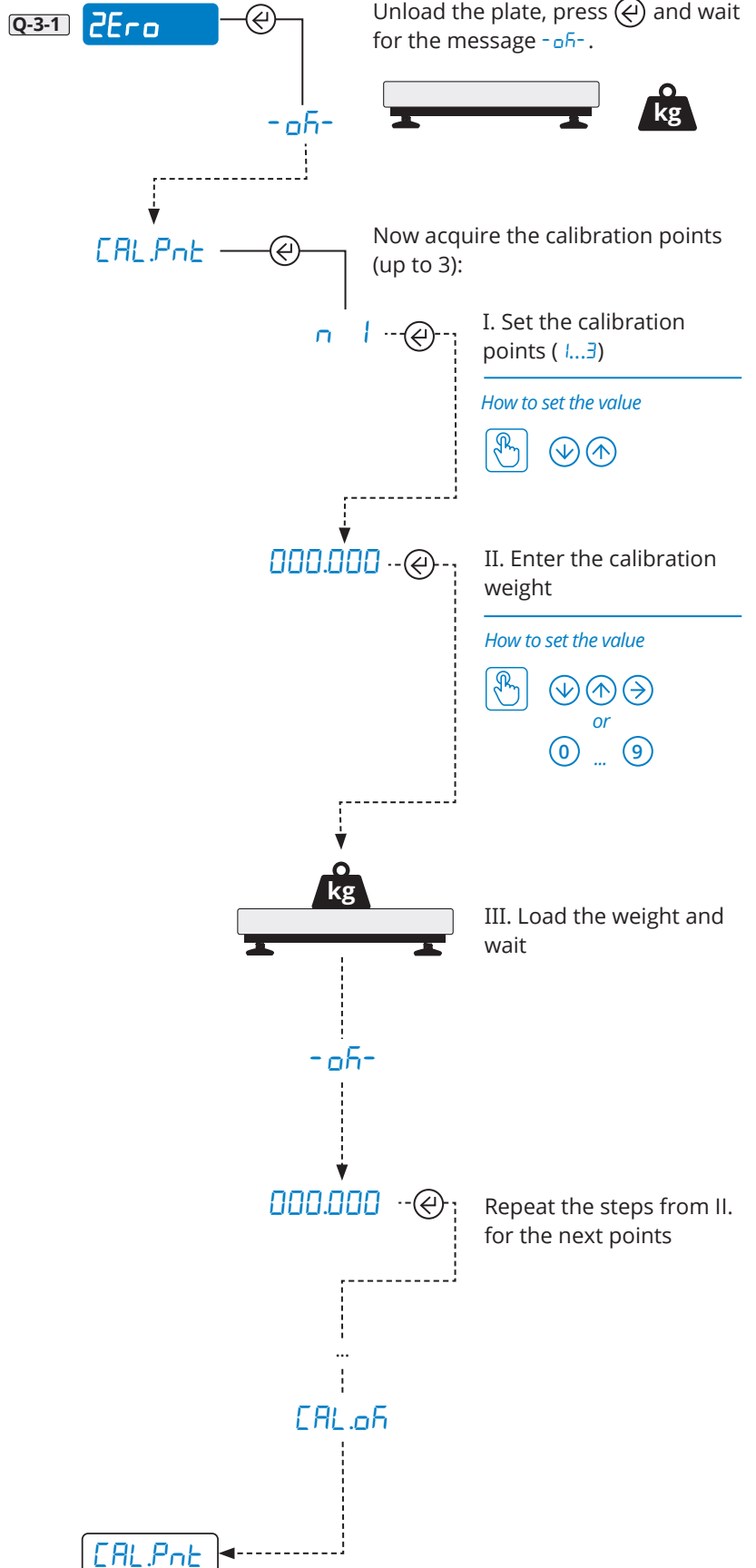
Start of the calibration procedure:











How to enter

1. Off 
2. On 
3. 

 Page 8

How to browse

-  = 
-  = 
-  = 
-  = 

How to save and exit



 Page 8

A CAL

B O.CAL

C GrAU

D SEr iAL

E LAYout

F FiLteR

G SCrEEen

H bAtte

I ECoBAte

J AutoFF

K rENotE

L An.out

M inPutS

N outPut

O rESEt

P d iAG

Q AdUAnC

1 CAL.PAr

2 E9uAL.P

3 CAL.AdU

4 NEtrol

5 KEyb

6 t iLte

7 rEAct

8 LoCkAb

9 AL ib i.r

10 P in.tEC

11 P in.wSE

12 dFLt.t

1 OPErC

2 d iUStb

3 O.trh

4 on.2Ero

5 CAL.AdU

6 CAL.MAn

7 d.SALE



Reset percentage via key

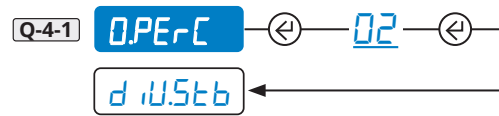

With approved scale (0...2)  
With non-approved scale (0...50)

Sensitivity of the weight stability control

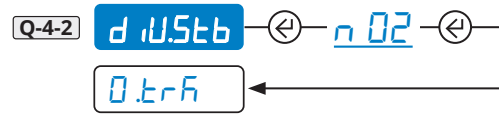

(0...99)

Zero hold function (tracking)

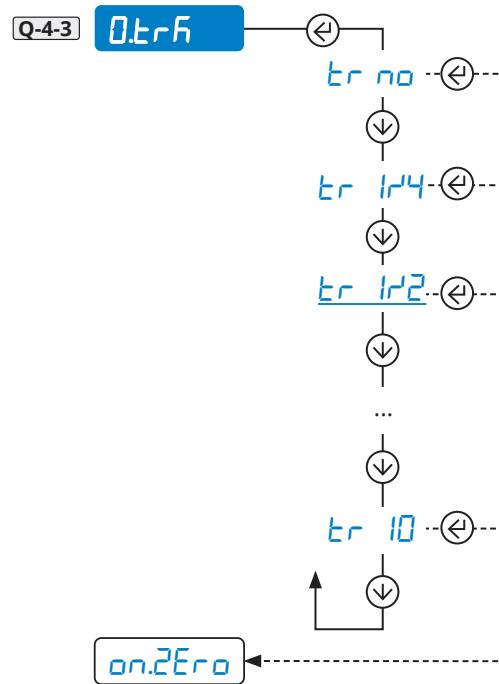

# MENU

How to enter

1. Off
2. On
- 3.

Page 8

How to browse

- ↑ =
- ↓ =
- =
- ← =

How to save and exit



Page 8

- A CAL
- B D.CAL
- C GrAU
- D SEr iAL
- E LAYout
- F FiLteR
- G SCrEEen
- H bAtte
- I ECoBat
- J AutoFF
- K rENotE
- L An.out
- M inPutS
- N outPut
- O rESEt
- P d iAG
- Q AdUAnC

- 1 CAL.PAr
- 2 EQuALP
- 3 CAL.AdU
- 4 NEtroL
- 5 KEyb
- 6 t iLt
- 7 rEAct
- 8 LoCkAb
- 9 AL ib i.r
- 10 P intEC
- 11 P inuSE
- 12 dFLt.t
- 1 OPErC
- 2 d iUStb
- 3 O.t rH
- 4 on.2Ero
- 5 CAL.AdJ
- 6 CAL.NAn
- 7 d.SALE

Reset at power and reset percentage

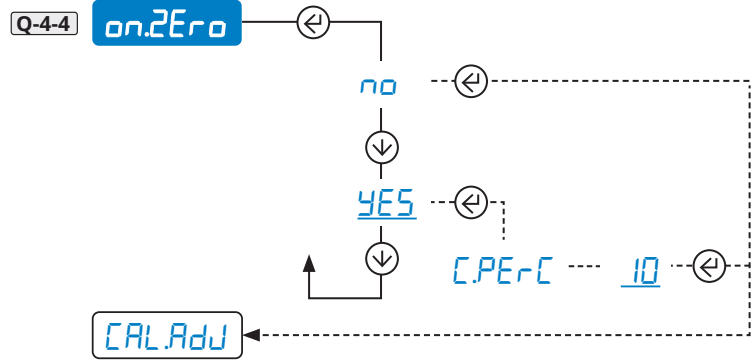

Re-acquisition / change of the calibration points in memory.

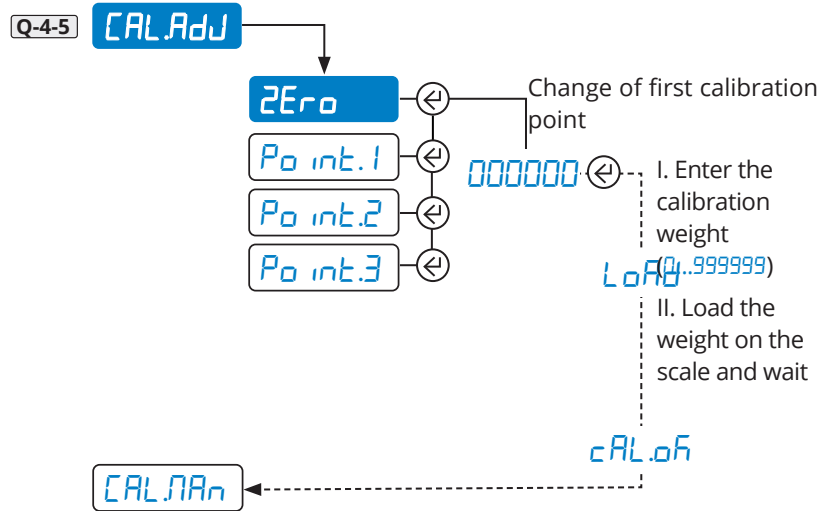

Repeat the same operation for Po int 1, Po int 2 e Po int 3

Q-4-6 CAL.NAn For use by the manufacturer.

Q-4-7 d.SALE For use by the manufacturer.

Type of keyboard

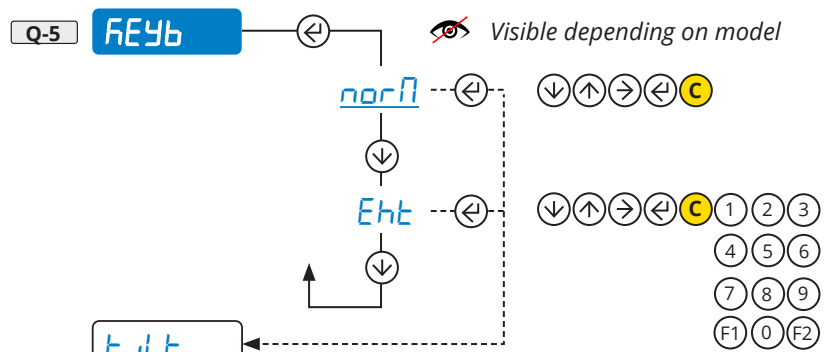

Inclinometer (for use by the manufacturer)

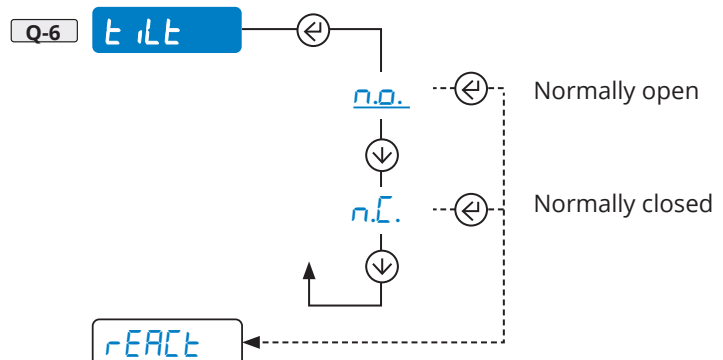



# MENU

How to enter

1. Off
2. On
- 3.

Page 8

How to browse

- =
- =
- =
- =

How to save and exit



Page 8

A CAL

B 0.CAL

C GrAU

D SEr iAL

E LAYout

F FiLteR

G SCrEEen

H bAtte

I ECobAt

J AutoFF

K rENotE

L An.out

M inPutS

N outPut

O rESEt

P d iAG

Q AdUAnC

1 CAL.PAr

2 EQwAL.P

3 CAL.AdU

4 nEtrol

5 rEYb

6 t iLl

7 rEAct

8 LoCkAb

9 AL iB iR

10 P in.tEC

11 P in.uSE

12 dFLt.t

## Reactivation of the totalisation or print function

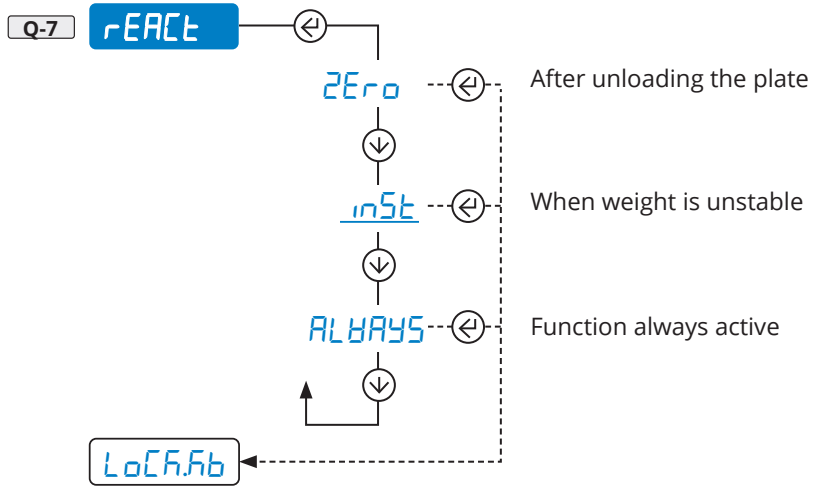

## Permanent keyboard lock (excluding key )

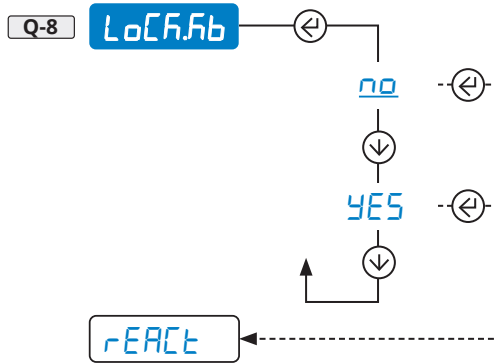

## Reset of fiscal memory (alibi memory, optional)

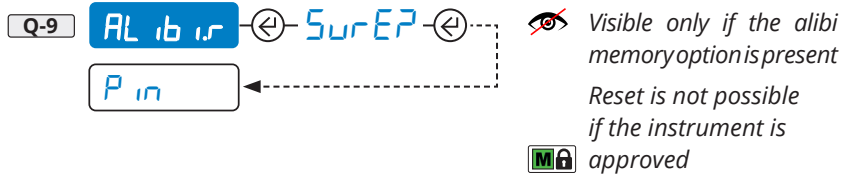

## Access PIN to programming menu

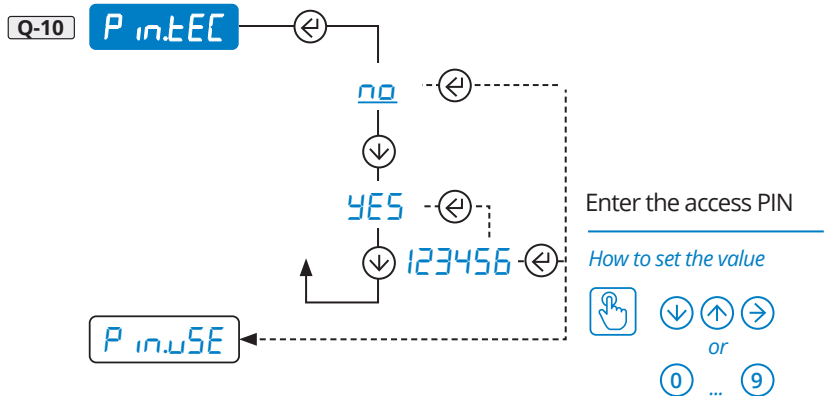

## Access PIN to user menus



## Total reset of memory and of calibration, with reset of the factory settings.

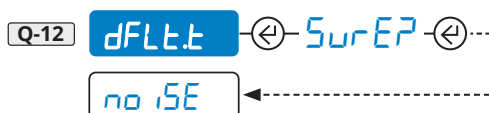

## 6. COMMUNICATION STRINGS

### Short string

**01ST,GS, 0.0,kg<CR><LF>**

where

<b>01</b>	Code 485 of the instrument (2 characters), only if communication mode 485 is enabled
<b>ST</b>	Scale status (2 characters): <u>US</u> - Weight unstable <u>ST</u> - Weight stable <u>OL</u> - Weight overload (out of range) <u>UL</u> - Weight underload (out of range) <u>TL</u> - Scale not level (inclinometer active)
<b>,</b>	ASCII 044 character
<b>GS</b>	Type of weight data (2 characters) <u>GS</u> - Gross <u>NT</u> - Net
<b>,</b>	ASCII 044 character
<b>0.0</b>	Weight (8 characters including the decimal point)
<b>,</b>	ASCII 044 character
<b>kg</b>	Unit of measurement (2 characters)
<b>&lt;CR&gt;&lt;LF&gt;</b>	Transmission terminator, characters ASCII 013 and ASCII 010

### Extended string

**011, ST, 0.0,PT 20.8, 0,kg<CR><LF>**

where

<b>01</b>	Code 485 of the instrument (2 characters), only if communication mode 485 is enabled
<b>1</b>	ASCII 049 character
<b>,</b>	ASCII 044 character
<b>ST</b>	Scale status (2 characters): <u>US</u> - Weight unstable <u>ST</u> - Weight stable <u>OL</u> - Weight overload (out of range) <u>UL</u> - Weight underload (out of range) <u>TL</u> - Scale not level (inclinometer active)
<b>,</b>	ASCII 044 character
<b>0.0</b>	Net weight (10 characters including the decimal point)
<b>,</b>	ASCII 044 character
<b>PT</b>	Indication of pre-set manual tare (2 characters)
<b>20.8</b>	Tare weight (10 characters including the decimal point)
<b>,</b>	ASCII 044 character
<b>0</b>	Number of pieces (10 characters)
<b>,</b>	ASCII 044 character
<b>kg</b>	Unit of measurement (2 characters)
<b>&lt;CR&gt;&lt;LF&gt;</b>	Transmission terminator, characters ASCII 013 and ASCII 010

## 7. COMMUNICATION CONTROLS

Premise:

in the serial controls and in the relative responses

<b>nn</b>	Address 485 of the instrument (2 characters) (only if communication mode 485 is activated)
<b>&lt;CR&gt;</b>	Terminator character ASCII 13 (0D) (1 character)
<b>&lt;LF&gt;</b>	Terminator character ASCII 10 (0A) (1 character)

### Reading of simple weight

<b>Control</b>	<b>nnREAD&lt;CR&gt;&lt;LF&gt;</b>
<b>Response</b>	Short string (see page 42)

### Reading of complete weight

<b>Control</b>	<b>nnREXT&lt;CR&gt;&lt;LF&gt;</b>
<b>Response</b>	Extended string (see page 42)

### Execution of a semi-automatic tare

<b>Control</b>	<b>nnTARE&lt;CR&gt;&lt;LF&gt;</b>
<b>Response</b>	<b>OK&lt;CR&gt;&lt;LF&gt;</b> indicates that the control was received correctly

### Setting of the tare value (PT)

<b>Control</b>	<b>nnTMANttttttt&lt;CR&gt;&lt;LF&gt;</b> Where <b>t...t</b> is the tare, with decimal points, max 8 characters.
<b>Response</b>	<b>OK&lt;CR&gt;&lt;LF&gt;</b> indicates that the control was received correctly
<b>Examples</b>	<b>TMAN1.56&lt;CR&gt;&lt;LF&gt;</b> set a tare of 1.56 <b>TMAN100&lt;CR&gt;&lt;LF&gt;</b> set a tare of 100

### Deleting the tare in memory

<b>Control</b>	<b>nnCLEAR&lt;CR&gt;&lt;LF&gt;</b>
<b>Response</b>	<b>OK&lt;CR&gt;&lt;LF&gt;</b> indicates that the control was received correctly

### Scale reset (function of the ZERO key)

<b>Control</b>	<b>nnZERO&lt;CR&gt;&lt;LF&gt;</b>
<b>Response</b>	<b>OK&lt;CR&gt;&lt;LF&gt;</b> indicates that the control was received correctly

## SPECIFIC CONTROLS FOR ALIBI MEMORY (OPTIONAL)

### Storage requests

<b>Control</b>	<b>nnPID&lt;CR&gt;&lt;LF&gt;</b> request to store the weight
<b>Response</b>	recording successful <b>nnPIDss,c,wwwwwwwwwwuu,ppttttttttuu,xxxxx-yyyyyy&lt;CR&gt;&lt;LF&gt;</b>
	no recording <b>nnPIDss,c,wwwwwwwwwwuu,ppttttttttuu,NO&lt;CR&gt;&lt;LF&gt;</b>
where:	
<b>ss</b>	status of weight (2 characters)
<b>TL</b>	Error of condition of <i>TL</i> (NO RECORDING)
<b>OL</b>	Condition of <i>OL</i> (NO RECORDING)
<b>UL</b>	Condition of <i>UL</i> (NO RECORDING)
<b>ST</b>	Weight stable
<b>US</b>	Weight unstable (NO RECORDING)
<b>c</b>	Scale number (1 character)
<b>w...w</b>	Gross weight (10 characters)
<b>uu</b>	Unit of measurement (2 characters)
<b>pp</b>	Type of tare: double space " " if semi-automatic, "PT" if pre-set (2 characters)
<b>t...t</b>	Tare value (10 characters)
<b>xxxxx</b>	Number of rewriting (5 characters)
<b>yyyyyy</b>	Progressive weighted (6 characters)
<b>Examples</b>	PIDST,1, 1500,0kg,PT 2,8kg,00000-000158<CR><LF> PIDUS,1, 1500,0kg,PT 2,8kg,NO<CR><LF>

### Reading of a weighing in memory

<b>Control</b>	<b>nnALRDxxxxx-yyyyyy&lt;CR&gt;&lt;LF&gt;</b> Where <b>xxxxx</b> is the rewriting number, <b>yyyyyy</b> is the progressive weighted.
<b>Response</b>	<b>s, w w w w w w w w w w u u , p p t t t t t t t t t t u u&lt;CR&gt;&lt;LF&gt;</b>
where:	
<b>s</b>	Number of scales (always 1)
<b>w...w</b>	Gross weight (10 characters)
<b>uu</b>	Unit of measurement ("g", "kg", "t", "lb")
<b>pp</b>	Type of tare: double space " " if semi-automatic, "PT" if pre-set (2 characters)
<b>t...t</b>	Tare value (10 characters)
<b>Examples</b>	ALRD00000-000158<CR><LF> 1, 1500,0kg, 2,8kg<CR><LF>

# 8. WIRING SCHEMES

DFWL<sub>xxx</sub>, WLB, TPWN<sub>xxx</sub>, TPWL<sub>xxx</sub>, MCWN<sub>xxx</sub>.

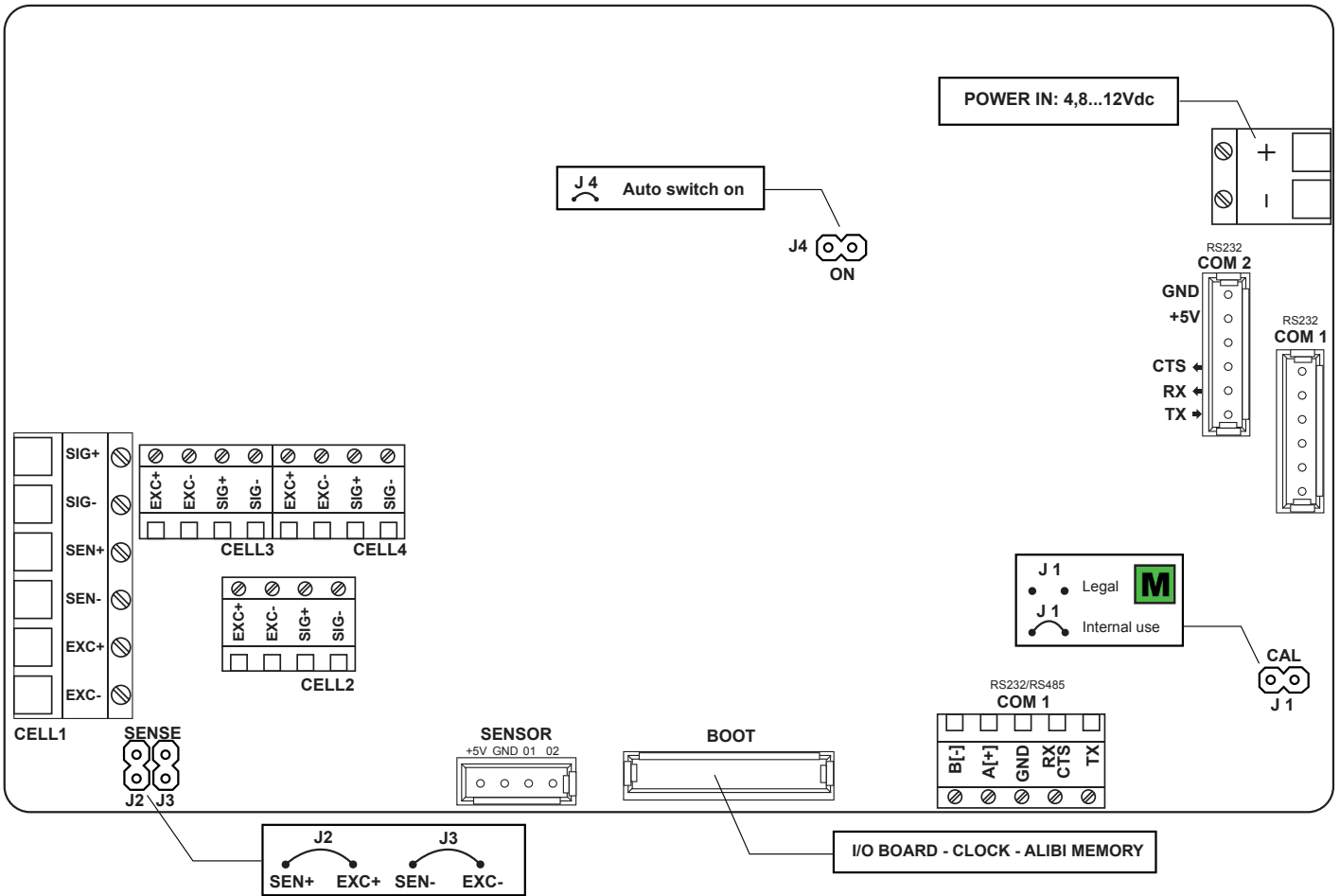

DFWLID<sub>xxx</sub>

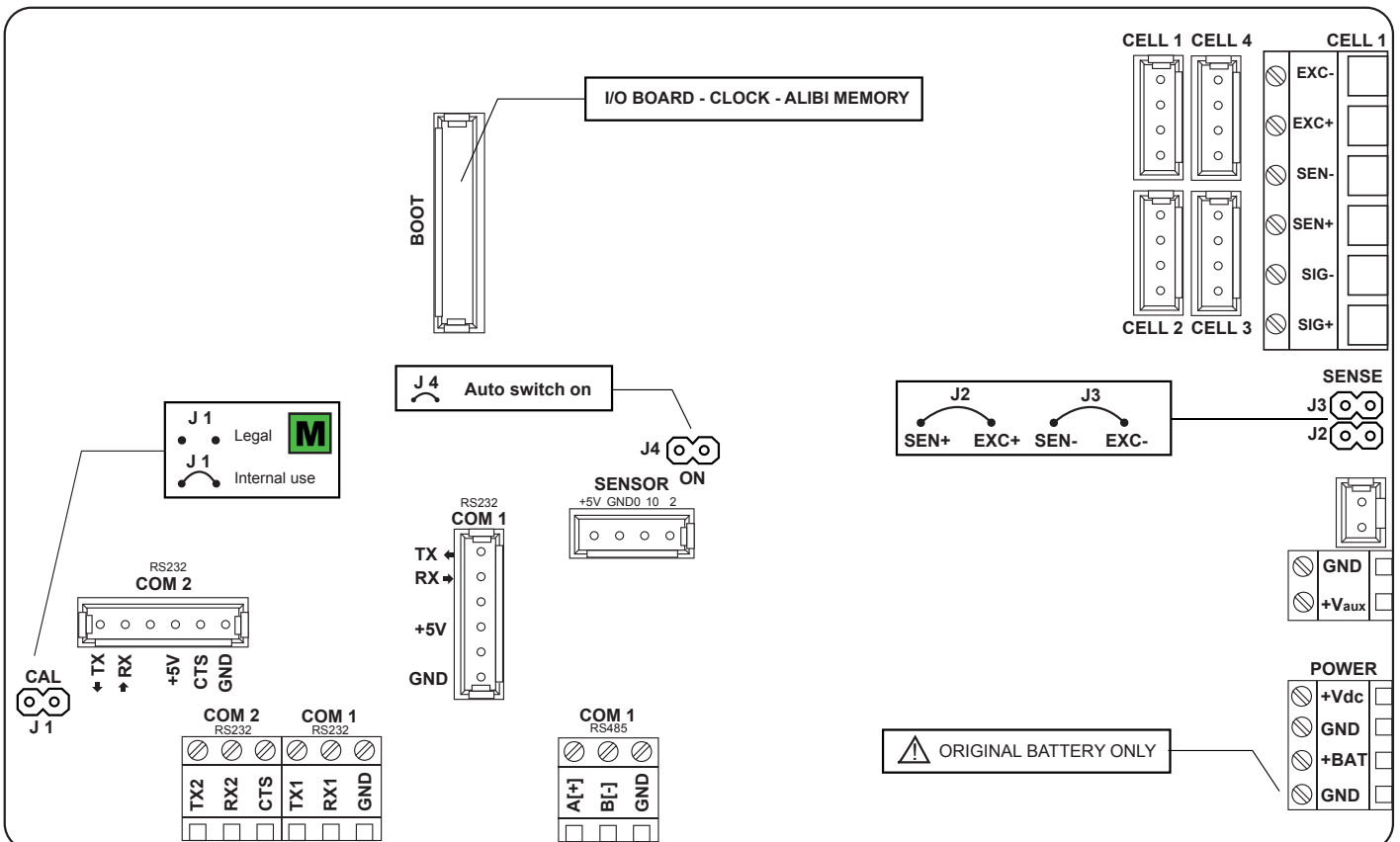

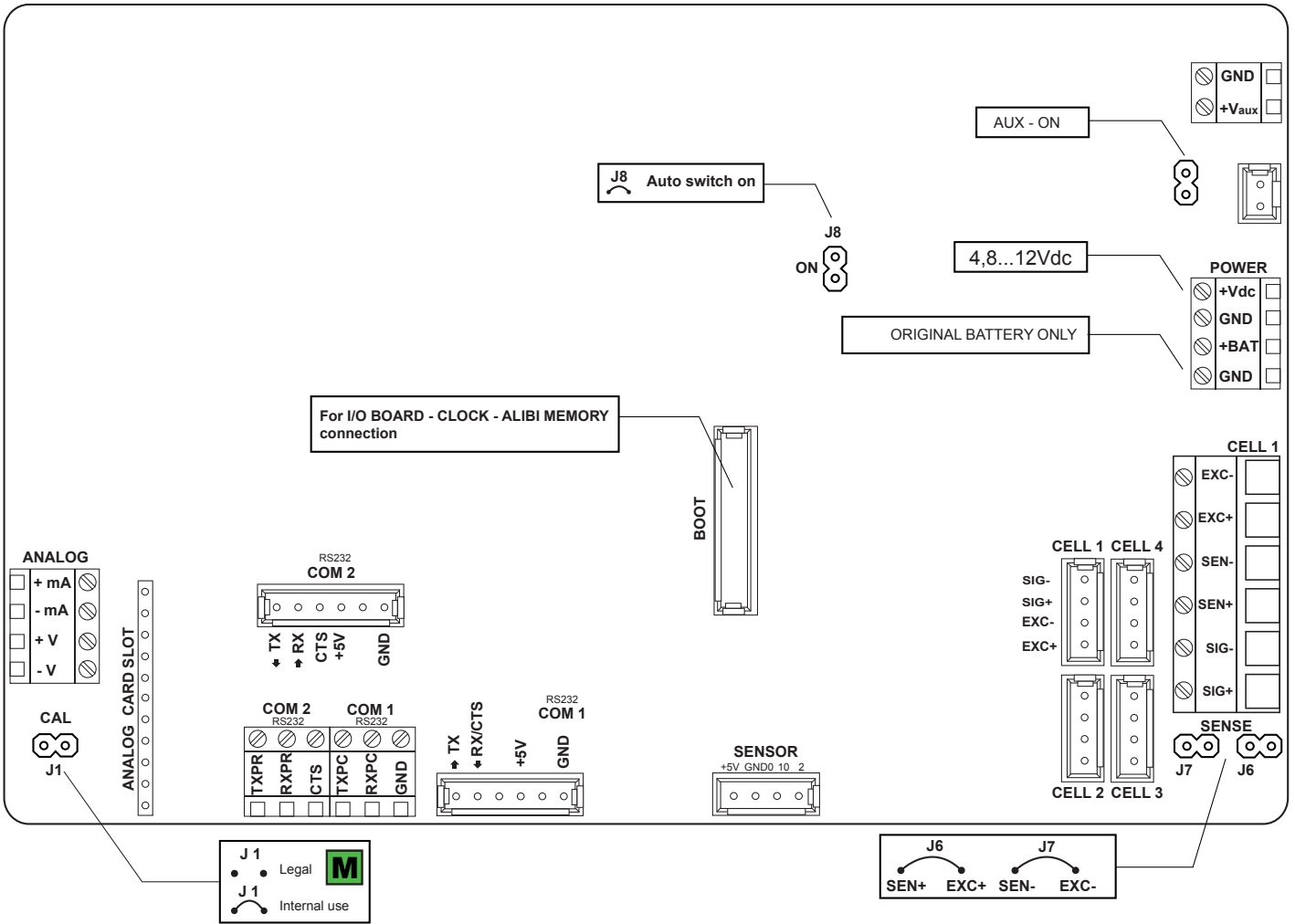

**RS232 serial port with RJ11 connector**

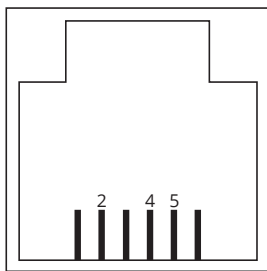

PIN	MEANING
2	TX
4	GND
5	RX

**Optional IN/OUT board DFIO**

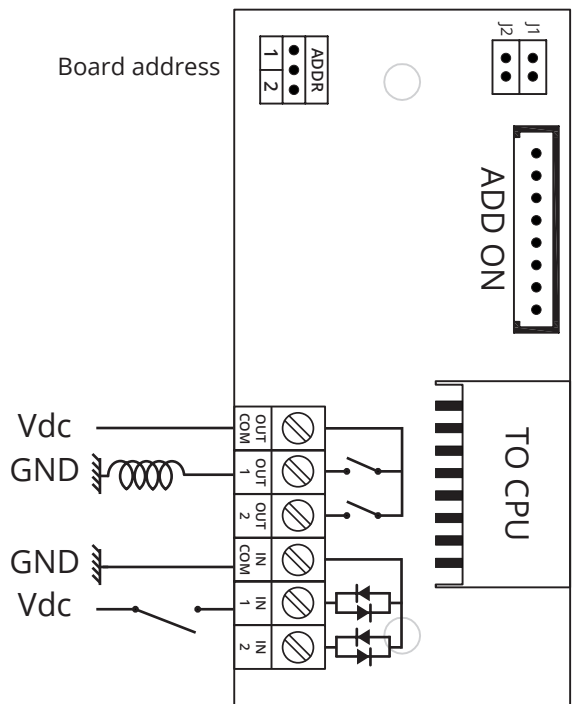

# Battery switch board

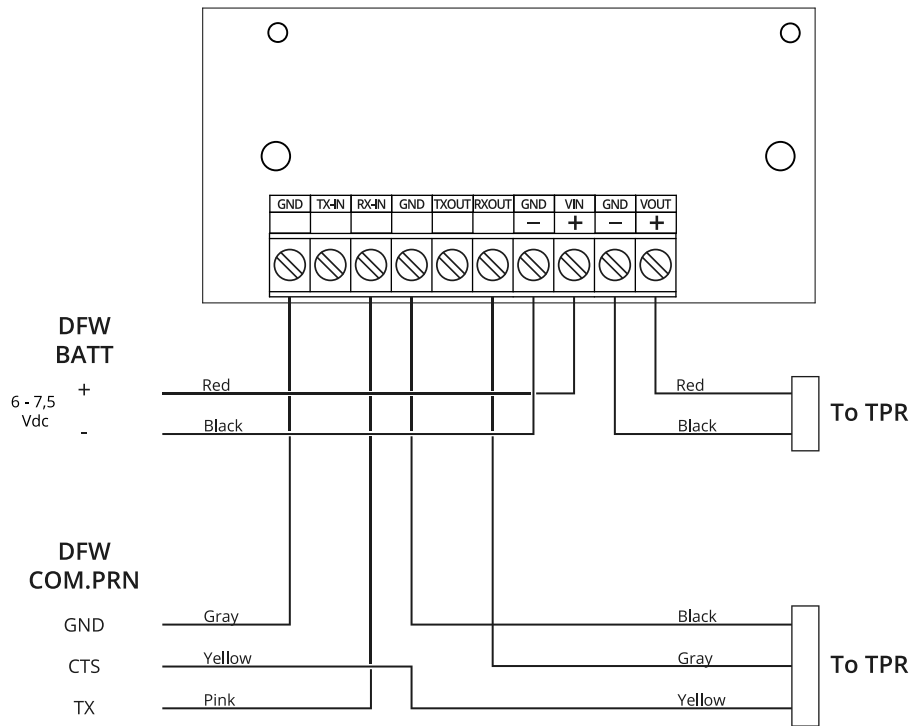

## 9. PROGRAMMING ERRORS

MESSAGE	DESCRIPTION	SOLUTION
<i>AL.Err</i>	Board "alibi memory" (optional) not detected.	Check the presence of the board inside the indicator. If present, check it is not damaged and is installed correctly.
<i>Er.1b.H</i>	Board "inputs/outputs" (optional) not detected.	Check the presence of the board inside the indicator. If absent, deactivate any inputs or outputs (parameter " <i>inPut5</i> " or " <i>outPut</i> ", see page 32-33). If present, check it is not damaged and is installed correctly.
<i>Err.b.H</i>		
<i>E9.Err</i>	Impossible to perform equalisation.	Check the cells are connected properly. Check the signal of each cell in the diagnostic menu (menu <i>d.AG</i> , parameter <i>AdC.uU</i> , see page 34).
<i>Pr.EC.</i>	Calibration error.	First calibrate the zero point, then proceed with the next points.
<i>Err.Pnt</i>	Calibration error.	Check the connection of the load cell. Check that the cell signal is stable, valid and greater than that of the previously acquired point.
<i>Er 11</i>	Calibration error.	Increase the calibration weight.
<i>Er 12</i>	Calibration error.	Check that the signal coming from the cell increases upon the increasing of the weight loaded on the scale. When acquiring the calibration points, use the increasing calibration weights.
<i>Er 37</i>	Calibration error.	Repeat the calibration, checking that the capacity and division have been correctly set.
<i>Er 39</i>	Instrument not configured.	Reset the factory configurations (menu <i>AdUAnC</i> , parameter <i>dFLtE</i> , see page 41).
<i>Er 85</i>	Instrument configured but not calibrated.	Perform calibration.
<i>[Er. 36</i>	Calibration error.	Check that the signal coming from the load cell is not negative.
<i>Err.NoI</i>	Weight unstable.	Check in menu <i>d.AG</i> , parameter <i>AdC.uU</i> (see page 34) that the signal is stable and re-try. If the connection of the cells is with 4 wires, check that the sense jumpers are inserted.



# 10. SUMMARY OF THE PARAMETERS

<b>CAL</b>	Calibration.....	10
<b>d iU</b>	Division .....	10
<b>0.CAL</b>	Reset of Pre-Tare (zero calibration).....	11
<b>GrAU</b>	Area of gravity of the place of use.....	11
<b>SEr iAL</b>	Configuration of the serial ports .....	12
<b>CoN.PC</b>	Communication with PC, PLC or repeater .....	12
<b>ModE</b>	Selection of the communication mode .....	12
<b>CoN.SEL</b>	Selecting the COM port for connection with PC/PLC.....	13
<b>bAud</b>	Communication speed (baud rate).....	13
<b>b it</b>	Configuration of the serial protocol .....	13
<b>CoN.Prn</b>	Communication with printer or repeater or PC.....	14
<b>ModE</b>	Selection of the communication mode .....	14
<b>bAud</b>	Communication speed (baud rate).....	14
<b>b it</b>	Configuration of the serial protocol .....	15
<b>CtS</b>	Printer control signal.....	15
<b>POWEr.P</b>	Printer power supply / radio-frequency module .....	15
<b>AdUAnC</b>	Advanced configurations.....	16
<b>ProtoC</b>	Communication protocol.....	16
<b>rAd io</b>	Connection port of radio-frequency module (for use by the manufacturer).....	16
<b>tEtL.t iL</b>	TTL port / Inclinator activation (for use by the manufacturer).....	16
<b>tEErA</b>	Closing character of each print line.....	16
<b>iGnorE</b>	Ignore unknown commands .....	17
<b>LAYout</b>	Print customisation .....	18
<b>LANg</b>	Setting of the print language ( <i>ITAL, ENGL, dEut, FrAn, ESPr, Ch inES</i> ) .....	19
<b>ChAr</b>	Setting the character .....	19
<b>hEAdEr</b>	Print header.....	20
<b>dAtA</b>	Selection of the weight data.....	22
<b>BE iGht</b>	Progressive weighed .....	22
<b>t iCkEt</b>	Receipt / label progressive .....	22
<b>CLoCh</b>	Date and time.....	23
<b>bAr.C39</b>	Bar code 39.....	23
<b>bAr.CuP</b>	Barcode top margin (mm) .....	23
<b>bAr.CL</b>	Barcode left margin (mm).....	23
<b>bAr.Ch</b>	Barcode height (mm).....	23
<b>bAr.Cdt</b>	Selection of the weight data.....	24
<b>CoP iES</b>	Multi-copy prints.....	24
<b>End.t iC</b>	Paper outlet for end of label / receipt.....	24
<b>bL inE</b>	White pre-heating line of the print head (for thermal printer only).....	24
<b>LABEL</b>	Label configuration.....	25
<b>Lb.SAVE</b>	Saving of labels in the printer memory.....	25
<b>tEst</b>	Saving of labels in the printer memory and test print of all formats .....	25
<b>F iLtEr</b>	Weighing filters.....	26
<b>SCrEEr</b>	Adjusting the display.....	27
<b>bAFL it</b>	Backlighting .....	27
<b>br iGht</b>	Brightness.....	27
<b>LoCh</b>	Display lock (for use by the manufacturer) .....	27
<b>CoLour</b>	Backlighting colour (in versions with colour display) .....	27

<b>bAtt</b>	Power supply via battery.....	28
<b>ECobAtt</b>	Energy saving for battery operation .....	28
<b>AutoOFF</b>	Auto off.....	29
<b>rEMote</b>	Remote control.....	29
<b>An.out</b>	Analog output.....	30
<b>inPuTs</b>	Digital inputs.....	32
<b>outPut</b>	Digital outputs.....	33
<b>rESEt</b>	Factory configuration reset.....	34
<b>d iAG</b>	Diagnostics.....	34
<b>AdC.uU</b>	Converter.....	34
<b>d iSPLA</b>	Display.....	34
<b>KEYb</b>	Keyboard.....	34
<b>AdUAnC</b>	Advanced.....	35
<b>CALPAR</b>	Calibration parameters.....	35
<b>dEC iN</b>	Configuration of the decimal point.....	35
<b>d iU</b>	Reading division .....	35
<b>u.N.</b>	Unit of measure .....	35
<b>rAnGE 1</b>	Scale capacity (maximum capacity / first weighing range).....	36
<b>rAnGE 2</b>	For multirange scales (second weighing range).....	36
<b>rAnGE 3</b>	For multirange scales (third weighing range).....	36
<b>EQuAL</b>	Equalisation function.....	36
<b>n.ChAn</b>	Equalised analog channels .....	36
<b>EQuALP</b>	Equalisation.....	37
<b>CALAdU</b>	Complete calibration.....	38
<b>MEtroL</b>	Metrological parameters .....	39
<b>OPeRC</b>	Reset percentage via key (⏴).....	39
<b>d iUStb</b>	Sensitivity of the weight stability control .....	39
<b>0tErH</b>	Zero hold function (tracking).....	39
<b>on.ZEro</b>	Reset at power and reset percentage .....	40
<b>CALAdJ</b>	Re-acquisition / change of the calibration points in memory .....	40
<b>CALMAn</b>	For use by the manufacturer.....	40
<b>dSALE</b>	For use by the manufacturer.....	40
<b>KEYb</b>	Type of keyboard .....	40
<b>t iLt</b>	Inclinometer (for use by the manufacturer).....	40
<b>rEAct</b>	Reactivation of the totalisation or print function .....	41
<b>LoCKAb</b>	Permanent keyboard lock (excluding key (C)).....	41
<b>AL iB iR</b>	Reset of fiscal memory (alibi memory, optional).....	41
<b>P inTEC</b>	Access PIN to programming menu.....	41
<b>P inUSE</b>	Access PIN to user menus .....	41
<b>dFLtE</b>	Total reset of the memory and of calibration.....	41

# 11. FAQ - FREQUENTLY ASKED QUESTIONS

## Calibration

---

### Can I change the maximum capacity without recalibrating?

Yes, you must change the parameters `rANGE 123` (Q-1-4,5,6). (See page 36)

### Can I change the division without recalibrating?

Yes, you must change the parameter `dIU` (Q-1-2). (See page 36)

### Can I change the position of the decimal point without recalibrating?

Yes, you must change the parameter `DEC n` (Q-1-1) and the value of the calibration points via the pitch `CAL.PPn` (Q-5-6). (See page 36 and 40)

### Can I calibrate the instrument in “multi-division” mode?

Yes, through advanced configuration from PC with Dinitools program.

## Communication

---

### Scale doesn't answer

- Check the good condition of the cable and that there are no failures (using a multimeter).
- Check that the PC communication port or of the device used is not compromised. If necessary, try with another device/PC
- Make sure to have connected the cable on the correct serial port.
- Check the configuration of the pitches `bAud` and `bIt`. (See page 13)
- Temporarily activate the continuous communication and retry receiving the string. If the string has been received correctly, carefully check the syntax of the control sent, the communication time-outs and the presence of the terminator.

## Generic

---

### The scale does not switch on

- Check that the input voltage level to the mother board is correct.
- Try the forced power by inserting the “ON BOOT” jumper present on the mother board. If the indicator lights up, check the correct operation of the keyboard, using the diagnostic menu `dIAG`. (See page 34)
- Possible failure of the internal rechargeable battery (if present).

# Notes

---

---

---

---

---

---

---

---

---

---

---

---

---

---

---

---

---

---

---

---

---

---

---

---

---

This publication, or portions thereof, may not be duplicated without written permission from the Manufacturer. All information contained in this manual is based on the data available at the time of its publication; the Manufacturer reserves the right to make changes to its products at any time without notice and without incurring any penalty. We therefore recommend that you always check for any updates.

The individual in charge of the scale operation must ensure that all safety regulations in force in the country of use are applied, ensuring that the appliance is used in accordance with the purpose it is intended for and to avoid any danger for the user.

The Manufacturer declines any liability arising from any weighing operation errors.









**HEAD OFFICE**

Via Della Fisica, 20  
41042 Spezzano di Fiorano, Modena - Italy  
Tel. +39 0536 843418 - Fax +39 0536 843521

**SERVICE ASSISTANCE**

Via Dell'Elettronica, 15  
41042 Spezzano di Fiorano, Modena - Italy  
Tel. +39 0536 921784 - Fax +39 0536 926654

[www.diniargeo.com](http://www.diniargeo.com)

Authorized service center stamp

